



EMS2000

Energy Management System

Installation Manual for the

43038 Motherboard and HVAC

Control Board

Version 1.7



Winn Energy Controls, Inc.

Section	Description	Page
1.0	Installation Guide for the 43038 Motherboard	
	Introduction	1 - 01
	Compatible Components	1 - 02
	Motherboard Features	1 - 04
	Installation Procedures	1 - 05
2.0	Wiring Diagrams	
	PC Computer to Control Modules (Communication Wiring)	2 - 01
	Master Control Unit to Control Modules (Communication Wiring)	2 - 02
	Master Control and PC Computer Local (Communication Wiring)	2 - 03
	Master Control On-Site / PC Off-Site (Communication Wiring)	2 - 04
	PC Computer to Internal Modem (Communication Wiring)	2 - 05
	Control Module Motherboard to Motherboard (Communication Wiring)	2 - 06
	Power Wiring to the Control Module Motherboard	2 - 07
	Room Temperature Sensor Wiring	2 - 08
	Supply and Roof Air Temperature Sensor Wiring	2 - 09
	HVAC Unit Terminal Wiring	2 - 10
	HVAC Unit Wiring (Gas/Electric System)	2 - 11
	HVAC Unit Wiring (Gas/Electric with Economizer System)	2 - 12
	HVAC Unit Wiring (Heat Pump System)	2 - 13
	HVAC Unit Wiring (Oil Furnace with A/C System)	2 - 14
	Backup Power Supply Wiring	2 - 15
	Wiring Workmanship Standard	2 - 16

EMS2000 Motherboard INSTALLATION GUIDE

Installation Instructions for the 43033 Motherboard

Introduction

This manual describes the installation and wiring of the 43038 Motherboards which are supplied in NEMA type enclosures. The 43038-212 Motherboard is powered by 12VAC and the 43038-224 is powered by 24VAC. Both models have connectors for a plug-in internal Modem board (43034) and an HVAC Control board (43030). The part numbers of compatible boards are shown in Table 1. Two-stage HVAC Control boards include an add-on economizer relay for control.

	12VAC	24VAC
Motherboard	43038-212	43038-224
HVAC Control Module, 1-Stage	43030-112	43030-124
HVAC Control Module, 2-Stage	43030-212	43030-224
Modem	43034-100	43034-100

Table 1. Part numbers for compatible 12VAC and 24VAC systems.

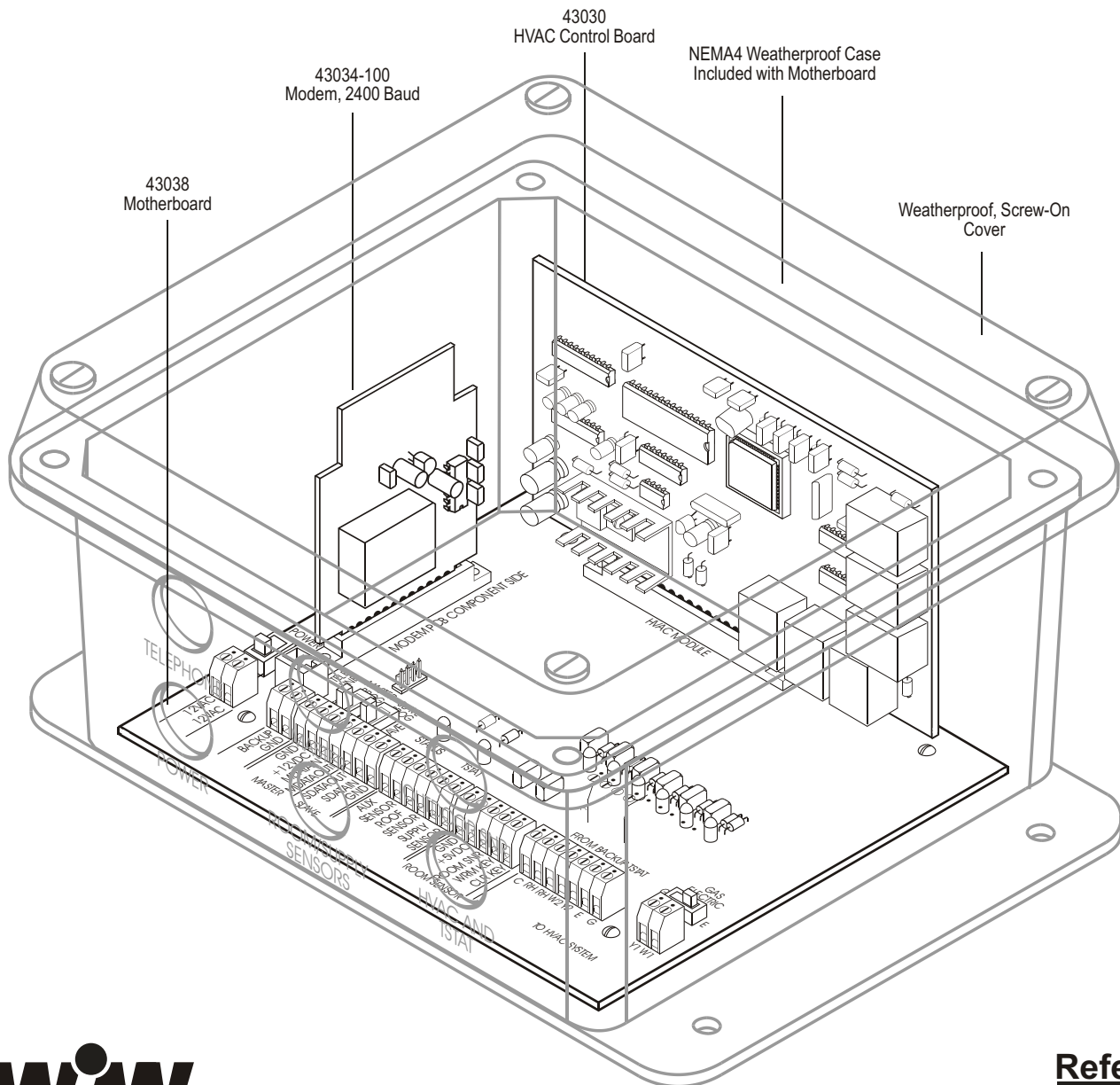

Reference
IG02

Compatible Components

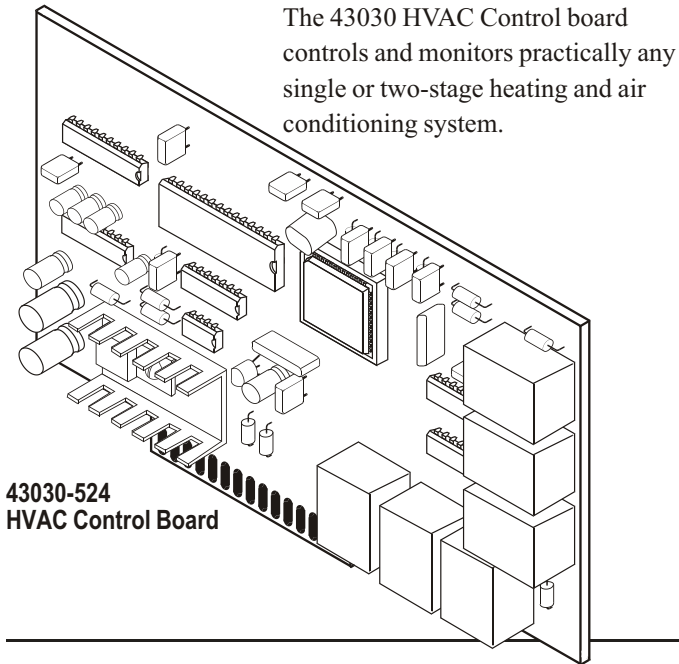

**43030-524
HVAC Control Board**

The 43030 HVAC Control board controls and monitors practically any single or two-stage heating and air conditioning system.

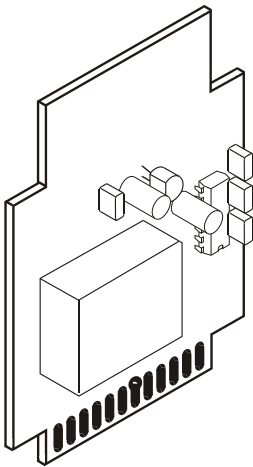

**43034-100
Internal Modem or Radio Board**

The 43034-100 Internal Modem or Radio board allows a string of HVAC Control boards and Analog/Digital Monitor boards to be monitored and controlled from a remote PC computer.

The 43025-100 Master Control Unit (MCU) can be used to control up to 32 units and display data from eight units. The MCU is primarily designed to control HVAC Control boards and has only limited control with the Analog/Digital Monitor board. Analog/Digital Monitor boards should be controlled with a local or remote PC computer and the Windows based EnergyPro software.

The MCU has an 8-pin RJ45 jack that can be connected to the external Modem (43034-200) or a PC computer running the EnergyPro software.

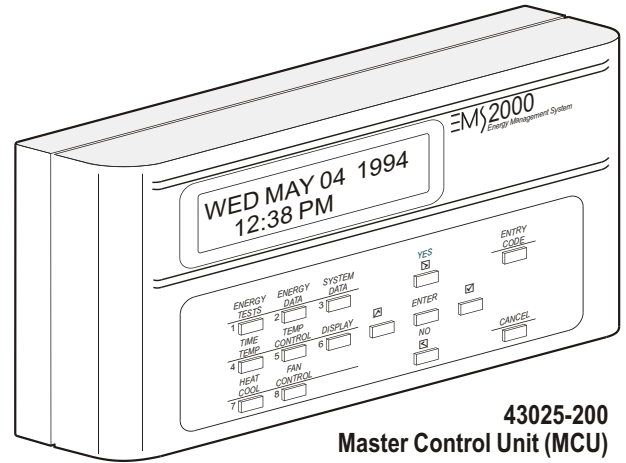

**43025-200
Master Control Unit (MCU)**

The 43034-200 external Modem can be used with the MCU and is connected with an 8-conductor RJ45 cable. The external Modem is powered through the cable to the MCU and does not require an AC adapter. An RJ11 jack is provided for connection to the telephone line.

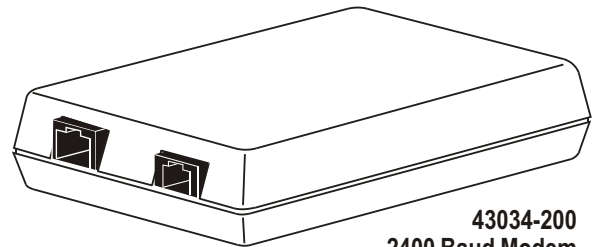

**43034-200
2400 Baud Modem**

A variety of Room Temperature Sensors can be used with the HVAC Control board to monitor indoor space temperature, display temperature and provide limited control over the heating and cooling setpoint temperatures.

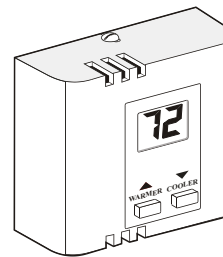

43021-300

The 43021-300 Room Temperature Sensor includes a thermistor type temperature sensor, a digital thermometer with LCD display and Warmer and Cooler keys for changing setpoint temperatures.

Temperature Sensors

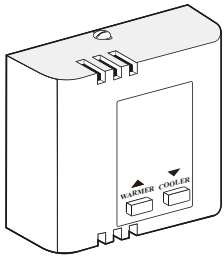

43021-200

The 43021-200 Room Temperature Sensor includes a thermistor type temperature sensor and Warmer and Cooler keys for changing setpoint temperatures.

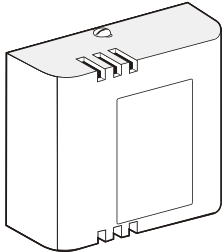

43021-100

The 43021-100 Room Temperature Sensor has a thermistor type temperature sensor for monitoring space temperature.

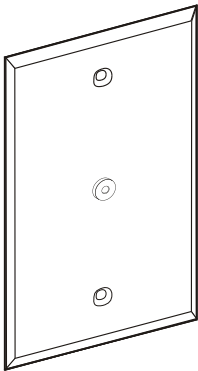

43102-100

The 43102 Room Temperature Sensor features an internal thermistor temperature sensor in a white, single wide, switch plate that can be attached to an electrical box or directly to a wall.

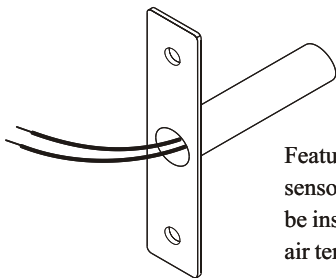

43103-100

Features an internal thermistor temperature sensor in a 3/8-inch diameter tube that can be installed in the duct to measure supply air temperature.

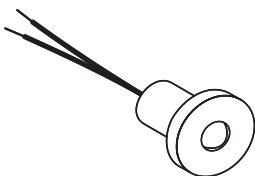

43104-100

Features an internal thermistor temperature sensor in a 3/8-inch diameter flanged, plastic bushing that can be installed in single-gang switch or in the NEMA enclosure to measure room temperature or outdoor air temperature.



43105-100

Features an internal thermistor temperature sensor in a copper lug that can be used to measure supply or outdoor air temperature.

Cables

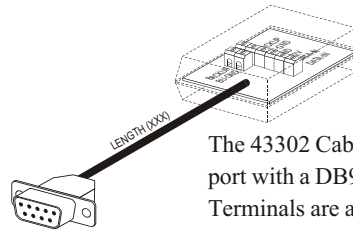

43302-XXX

The 43302 Cable connects the PC computer serial port with a DB9 connector to wire terminations. Terminals are also provided for backup power.

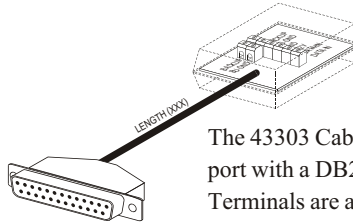

43303-XXX

The 43303 Cable connects the PC computer serial port with a DB25 connector to wire terminations. Terminals are also provided for backup power.

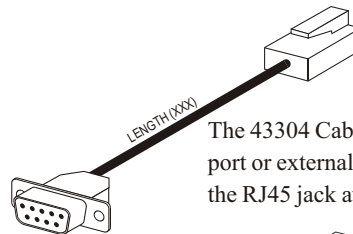

43304-XXX

The 43304 Cable connects the PC computer serial port or external Modem with a DB9 connector to the RJ45 jack at the bottom of an MCU.

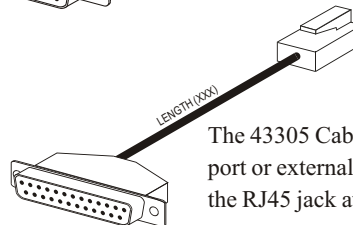

43305-XXX

The 43305 Cable connects the PC computer serial port or external Modem with a DB25 connector to the RJ45 jack at the bottom of an MCU.

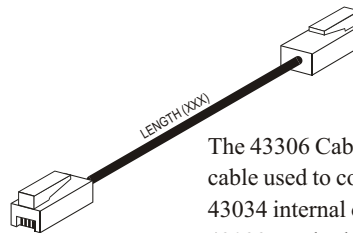

43306-XXX

The 43306 Cable is a standard 4-pin telephone cable used to connect the telephone line to the 43034 internal or external Modem or the 43032 or 43033 Motherboards.

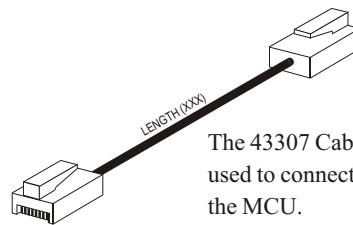

43307-XXX

The 43307 Cable is an 8-pin CAT-R patch cable used to connect the 43034-200 external Modem to the MCU.

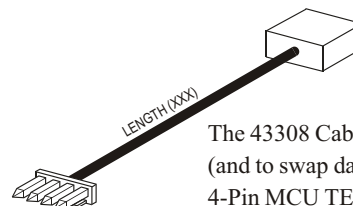

43308-XXX

The 43308 Cable is used as an extension cable (and to swap data lines) to connect an MCU to the 4-Pin MCU TEST connector on a Motherboard.

Motherboard Features

- ① **Power On/Off Switch**
Controls primary 12VAC or 24VAC power to the Motherboard. Does not control backup power.
- ② **RJ11 Telephone Jack**
Telephone jack for the plug-in internal Modem.
- ③ **Master Select Switch**
Selects RS232 input from the Master terminals (or Modem if installed) in the RUN position or the 4-pin MCU connector when in the PROG position.
- ④ **Slave Select Switch**
Isolates the Motherboard from other controls further down in the daisy chain. Used when programming the unit address.
- ⑤ **4-Pin MCU Connector**
An MCU with an extension cable (43308) can plug into Motherboard.
- ⑥ **Modem Connector**
The 43034-100 internal Modem plugs into the connector.
- ⑦ **Status LED for HVAC Control Board**
The LED blinks once a second to indicate the microcomputer is operating properly. It will blink rapidly during RS232 communications.
- ⑧ **Connector for HVAC Control Board.**
The 43030 HVAC Control board plugs into the connector.
- ⑨ **LED Indicators for HVAC Controls**
LEDs indicate when each HVAC control line (W1, Y1 etc.) is activated.

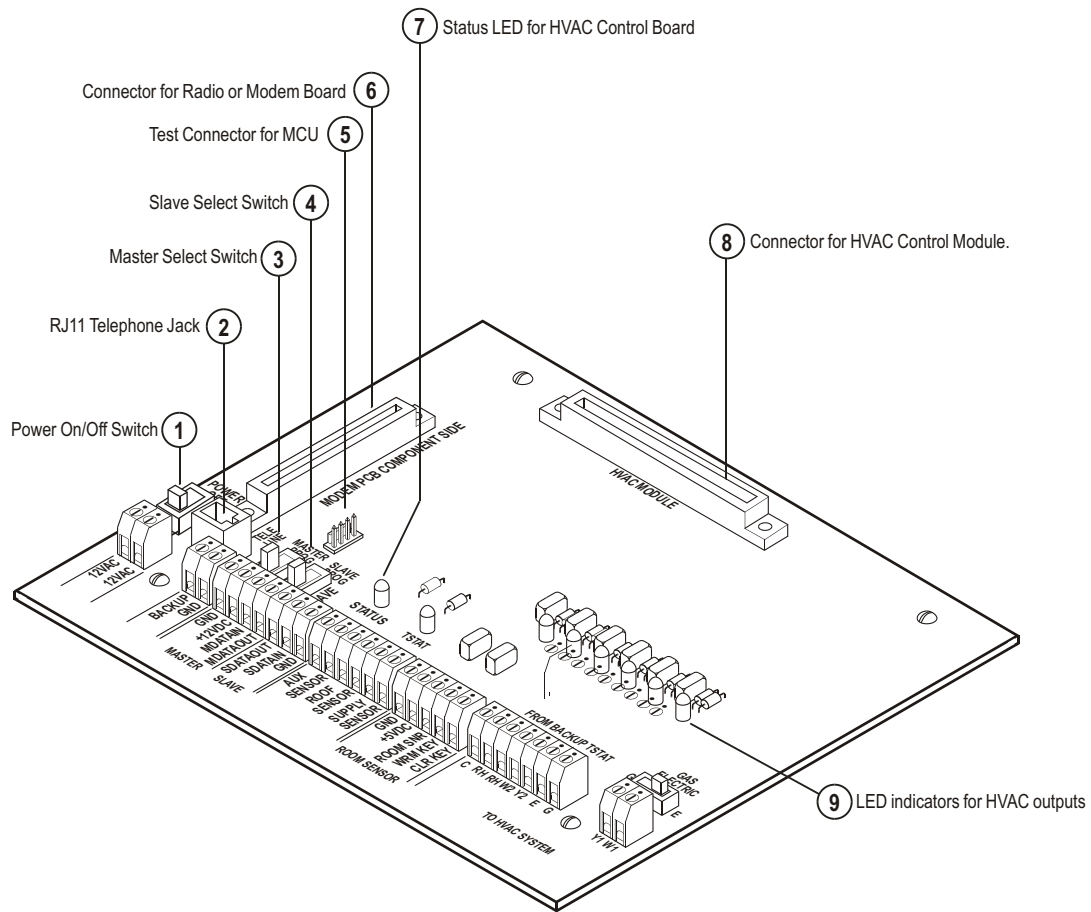

Before You Install the EMS2000 Control System

There are a number of options that should be selected before you install the EMS2000 control system and connect it to an HVAC system. The list below should help guide you through these options.

Program the Address

Each control board is programmed with an address so that data can be read from a specific control without affecting others. See your MCU manual or Software manual for detailed instructions. Default address is 01 for the HVAC Control board.

Program the Type of System

Each HVAC Control board should be programmed for the type of system it is controlling. Default is Gas/Electric.

Program the Economizer Enabled/Disabled and Economizer On Temperature

The economizer has to be enabled and the On temperature set if an economizer is being controlled by the HVAC Control board.

Program the Type of Modem

If a 43034-100 internal Modem is used in the Motherboard, the HVAC Control should be programmed for a Type 1 modem. This only applies to the first HVAC Control in the string, all others should be programmed to Type 0. Factory default is type 0 (no internal Modem connected).

Program the Alarm Options

Each control board has an alarm capability that can display alarm messages on the MCU LCD and optionally call a remote computer if a 43034-100 modem is used with the first Motherboard. See your Operations Manual or Software User's Guide for detailed instructions. Default is all alarms disabled, alarm delay = 10 minutes, repeat call timer = 30 minutes and set to display on the MCU LCD only.

Select the Type of Communications

The various control modules can be configured in a variety of configurations as shown in Wiring Diagrams WD01 through WD06. These selections will determine the hardware you use in a given application. The default settings will allow your system to operate with an MCU, PC computer or through a modem connected to the MCU.

Select the Operating Power

The Motherboards can be supplied to operate on either 12VAC or 24VAC.

Installing the Motherboard/NEMA Enclosure

The NEMA4 enclosure can be installed indoors or outdoors at the HVAC system. Four mounting holes are provided for #10 screws. If the unit is installed on the HVAC system be sure to verify that the mounting screws will not damage the HVAC system. The NEMA case is pre-drilled with 3/8 holes for routing the wiring as shown in Wiring Diagram WD19. For 1/2-inch conduit, use a Greenlee, 7/8-inch, panel punch to enlarge the holes.

Power Wiring

Wiring Diagram WD07 illustrates the wiring for both 12VAC and 24VAC operation. The 12VAC or 24 VAC transformer should be located within the HVAC unit's enclosure and its high voltage primary wiring should be insulated to local code.

Room Temperature Sensor Wiring

Wiring Diagram WD08 illustrates the wiring of the Room Temperature Sensor using a 43021-300 RTS. The GND, WRM and CLR wires may be omitted if only a temperature sensor is being used.

Supply Air Temperature Sensor Wiring

Wiring Diagram WD09 illustrates the wiring of the supply air temperature sensor. The sensors are not polarized and either wire may be connected to either terminal.

Roof Air Temperature Sensor Wiring

Wiring Diagram WD09 illustrates the wiring of the outdoor or roof air temperature sensor. The sensors are not polarized and either wire may be connected to either terminal. The 43104-100 may be used and will slip into one of the 3/8-inch diameter holes in the NEMA enclosure and can be secured with silicone adhesive.

HVAC System Wiring

Wiring Diagram WD11 shows the function of each output terminal on the Motherboard and their state during calls for heating and cooling with different types of equipment.

Wiring Diagrams WD12 through WD15 illustrate the HVAC system wiring for a variety of systems.

Communications Wiring

The Motherboards can communicate with Master Control Units (MCU), other Motherboards and a PC computer or Modem using RS232 serial data at 2400 baud. The length between any two communicating devices should not exceed 400 feet.

Wiring Diagrams WD01 through WD05 illustrate the connection of the first Motherboard in a string to an MCU, Modem or PC Computer. Wiring Diagram WD06 illustrates the connection between adjacent Motherboards.

Backup Power Wiring

The HVAC Control board store its settings in non-volatile memory. Whenever these settings are changed they are stored in non-volatile memory. Every 15 minutes the time and date is stored so that the time will be restored to within 15 minutes if a short term utility power failure occurs with no backup power.

The backup power can be a single high capacity (minimum of 1 amp) battery source connected to all units as illustrated in Wiring Diagram WD18 or a single 9v battery at each Motherboard.

System Startup and Test

After each Motherboard has been installed and connected to the HVAC system and other Motherboards, you should verify that the system is operating properly. The following steps should be helpful in commissioning and testing.

● Check Power Wiring

Turn the power breakers On and measure the DC voltage between the +5VDC terminal and any GND terminal. It should measure +5VDC \pm 5%. Measure the DC voltage between the +12VDC terminal and any GND terminal. It should measure 12VDC \pm 5%.

Measure the DC voltage between the +5VDC terminal and the sheet metal (earth ground), it should measure approximately 0VDC. If you measure 5VDC there is a short between signal GND and earth ground and you will have to find and remove the short.

● Check Master and Slave RS232 Wiring

You can verify the incoming or Master RS232 communications wiring by plugging an MCU into the 4-pin MCU Test Connector (see WD05) of the previous Motherboard and setting the Master switch to PROG.

Press the Energy Test key, select Y to Test Status Y/N? and select the address of the unit you are testing. The LCD will display the Test Day and Test Days if the communications is operating properly. This also checks the "Slave" communications from the previous unit.

If the LCD display shows RS232 ERROR the communications has not been established. Check that the wiring is correct and the address has been properly set. See the Operations Manual for instructions for setting the address.

● Check Sensor Wiring

You can read the various temperature sensors using the MCU or the PC computer with the EnergyPro software. See the Operations manuals for instructions. You can also measure the DC voltages at the sensor terminals. Table 1 shows the voltage you should measure between the temperature sensor terminals for different temperatures.

Temperature	Between ROOM SNR and +5VDC Terminals	Between SUPPLY SENSOR Terminals	Between ROOF SENSOR Terminals
60F	3.89VDC	3.89VDC	3.89VDC
65F	3.78VDC	3.78VDC	3.78VDC
70F	3.66VDC	3.66VDC	3.66VDC
75F	3.54VDC	3.54VDC	3.54VDC

Table 2. The nominal voltages measured at sensor terminals.

The voltages shown in Table 2 may vary somewhat and the polarity is not important. If you measure 0 or +5VDC there is a short (0VDC), an open connection (+5VDC), or a missing sensor (+5VDC).

● Check HVAC Wiring

The HVAC system wiring can be verified using the MCU to force a call for heating and observe that the correct LEDs on the Motherboard are On. Repeat this same procedure for the cooling system. To verify economizer operation, disconnect the outdoor temperature sensor (temperature will read 09) and force a call for cooling. Observe that the correct LEDs on the Motherboard are On.

●

Toll Free Helpline

If you have questions concerning the installation or operation of the EMS controls, please call:

(858) 274-1330 or (800) 770-2828.

Reference
IG02

EMS2000 Motherboard WIRING INSTRUCTIONS

Communications Wiring for the 43038 Motherboard

Using a PC Computer to Provide On-Site Control of HVAC Control Boards.

Description

A PC computer can be used to control a number of HVAC Control boards and Analog/Digital Monitor boards. A serial communications port on PC is connected to the first 43038 Motherboard as shown below. An adapter is required to convert the DB9 or DB25 connector for the computer's serial port to wire terminations.

Standard thermostat wire can now be used to connect the RS232 serial data from the computer to the Motherboard at the HVAC system provided it is less than 400 feet from the computer. Follow the wiring instructions as shown to the right.

The EnergyPro software User's Guide shows how to select and initialize a serial port in the PC computer and verify the integrity of the communications.

After plugging the 43302 or 43303 Cable adapter into the PC computer's serial port, connect the wires from the adapter to the 43038 Motherboard as follows:

At the Adapter Connect	To Motherboard Terminal	Wire Color	Function
GND	GND	WHT	Signal Ground
DATA-OUT	MDATA-IN	GRN	Data from the PC Computer
DATA-IN	MDATA-OUT	BLU	Data from the Motherboard
BACKUP	BACKUP	YEL	Backup Power to Motherboards
BU-GND	BU-GND	BRN	Ground for Backup Power

Neither +12VDC terminal should be connected. The Backup terminals should be wired as shown if a common backup power source is being used. See Wiring Back-Up Power.

Wiring Materials Required

1. Thermostat Wire, 4 or 6-Conductor, AWG20.
2. Cable adapter 43302 or 43303.

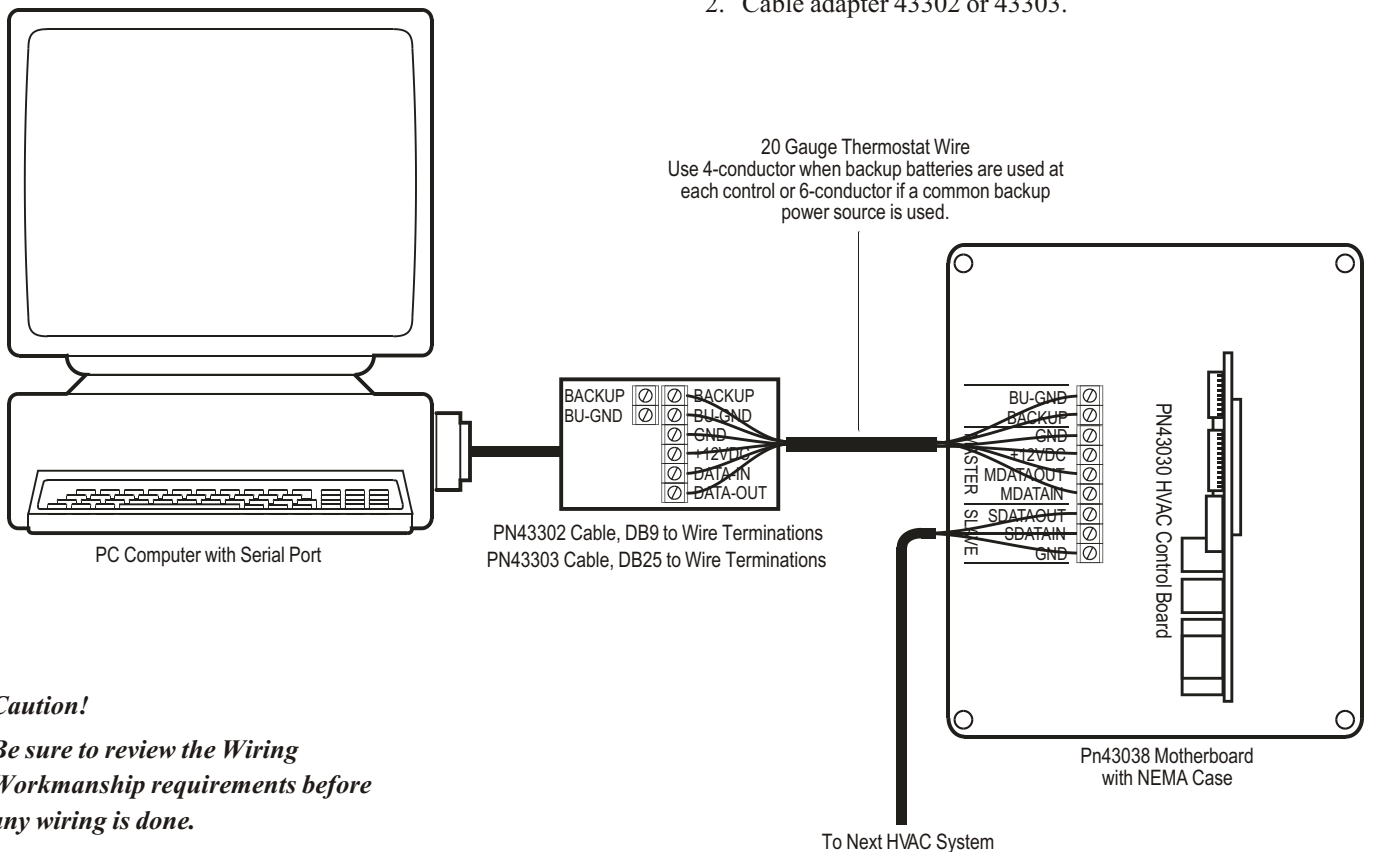

Caution!

Be sure to review the Wiring Workmanship requirements before any wiring is done.



EMS2000 Motherboard WIRING INSTRUCTIONS

Communications Wiring for the 43038 Motherboard

Using a Master Control Unit to Provide On-Site Control of HVAC Control Boards.

Description

A Master Control Unit (MCU) can be used to control up to eight Motherboards with HVAC Control boards. Data is transmitted using the RS232 format.

Standard thermostat wires should be used to connect the terminals on the MCU Sub-Base to the Motherboard at the first HVAC system provided it is less than 400 feet from the MCU. Follow the wiring instructions as shown to the right.

See Wiring Backup Power for instructions on wiring the BACKUP and BU-GND wires if a common backup power source is used.

After mechanically installing the MCU Sub-Base, connect the wires from the Sub-Base to the 43033 Motherboard as follows;

At the MCU Sub-Base	To Motherboard Terminal	Wire Color	Function
+12VDC	+12VDC	RED	+12V from HVAC Control Board
GND	GND	WHT	Signal Ground
DATA-OUT	MDATA-IN	GRN	Data from the PC
DATA-IN	MDATA-OUT	BLU	Data from the Motherboard
See text.	BACKUP	YEL	Backup Power to Motherboards
See text.	BU-GND	BRN	Ground for Backup Power

The Backup terminals should be wired as shown if a common backup power source is being used. See Wiring Back-Up Power.

Wiring Materials Required

1. Thermostat Wire, 4 or 6-Conductor, AWG20.

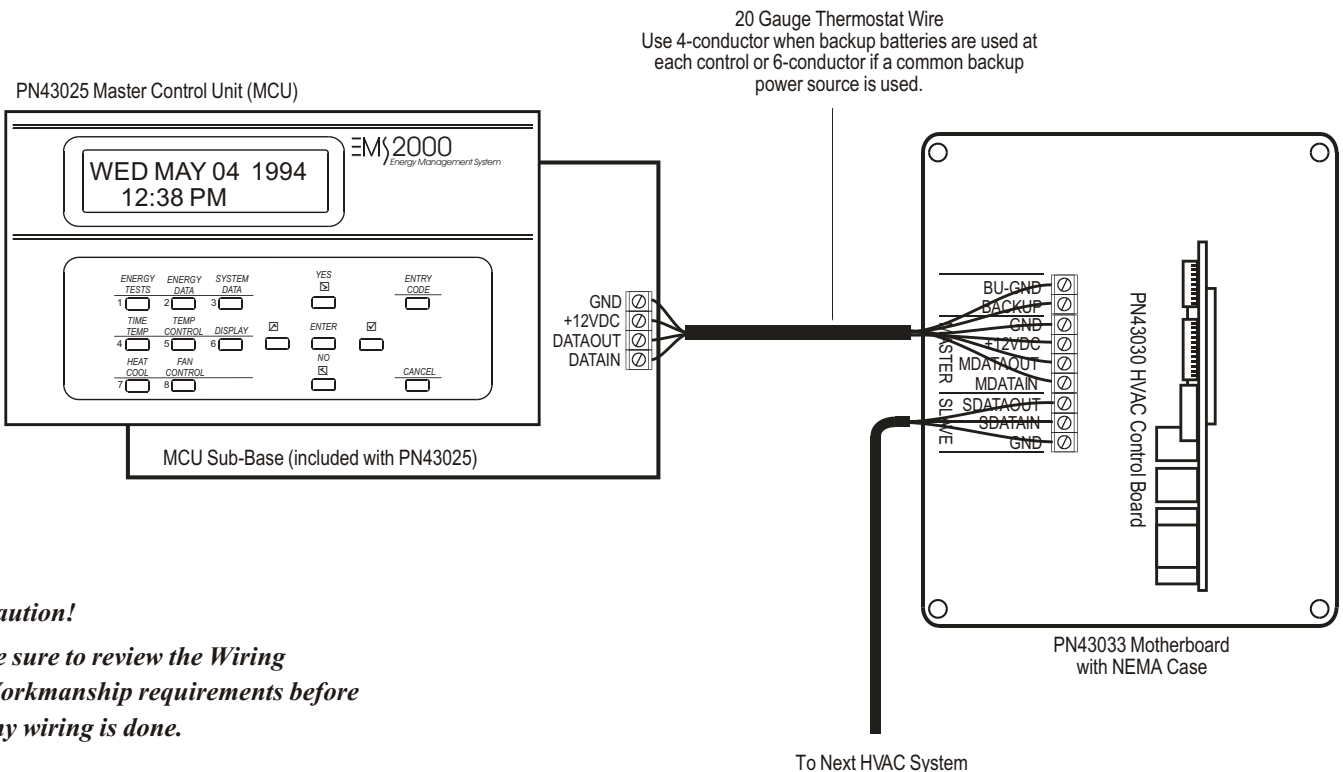

Caution!

Be sure to review the Wiring Workmanship requirements before any wiring is done.



Reference
WD02

EMS2000 Motherboard WIRING INSTRUCTIONS

Communications Wiring for the 43038 Motherboard

Using a Master Control Unit and PC to Provide On-Site Control of HVAC Control Boards.

Description

A Master Control Unit (MCU) and a PC computer can be used to control a number of Motherboards with HVAC Control boards and Analog/Digital Monitor boards. The MCU is limited to 8 Motherboards, although the computer can address up to 32 units on each serial port. The computer can be used to gather energy data and generate reports. The computer can be removed at any time without disturbing the performance of the system.

A 43304 or 43305 Cable connects the PC computer to the MCU. Standard thermostat wire can be used to connect the terminals on the MCU Sub-Base to the Motherboard at the HVAC system, provided it is less than 400 feet from the MCU. Follow the wiring instructions as shown to the right.

See Wiring Backup Power for instructions on wiring the BACKUP and BU-GND wires if a common backup power source is used.

After mechanically installing the MCU Sub-Base and installing the 43304 or 43305 Cable, connect the wires from the Sub-Base to the 43033 Motherboard as follows:

At the MCU Sub-Base	To Motherboard Terminal	Wire Color	Function
+12VDC	+12VDC	RED	+12V from HVAC Control Board
GND	GND	WHT	Signal Ground
DATA-OUT	MDATA-IN	GRN	Data from the PC Computer
DATA-IN	MDATA-OUT	BLU	Data from the Motherboard
See text.	BACKUP	YEL	Backup Power to Motherboards
See text.	BU-GND	BRN	Ground for Backup Power

The Backup terminals should be wired as shown if a common backup power source is being used. See Wiring Back-Up Power.

Wiring Materials Required

1. Thermostat Wire, 4 or 6-Conductor, AWG20.
2. Cable 43304 or 43305.

20 Gauge Thermostat Wire
Use 4-conductor when backup batteries are used at each control or 6-conductor if a common backup power source is used.

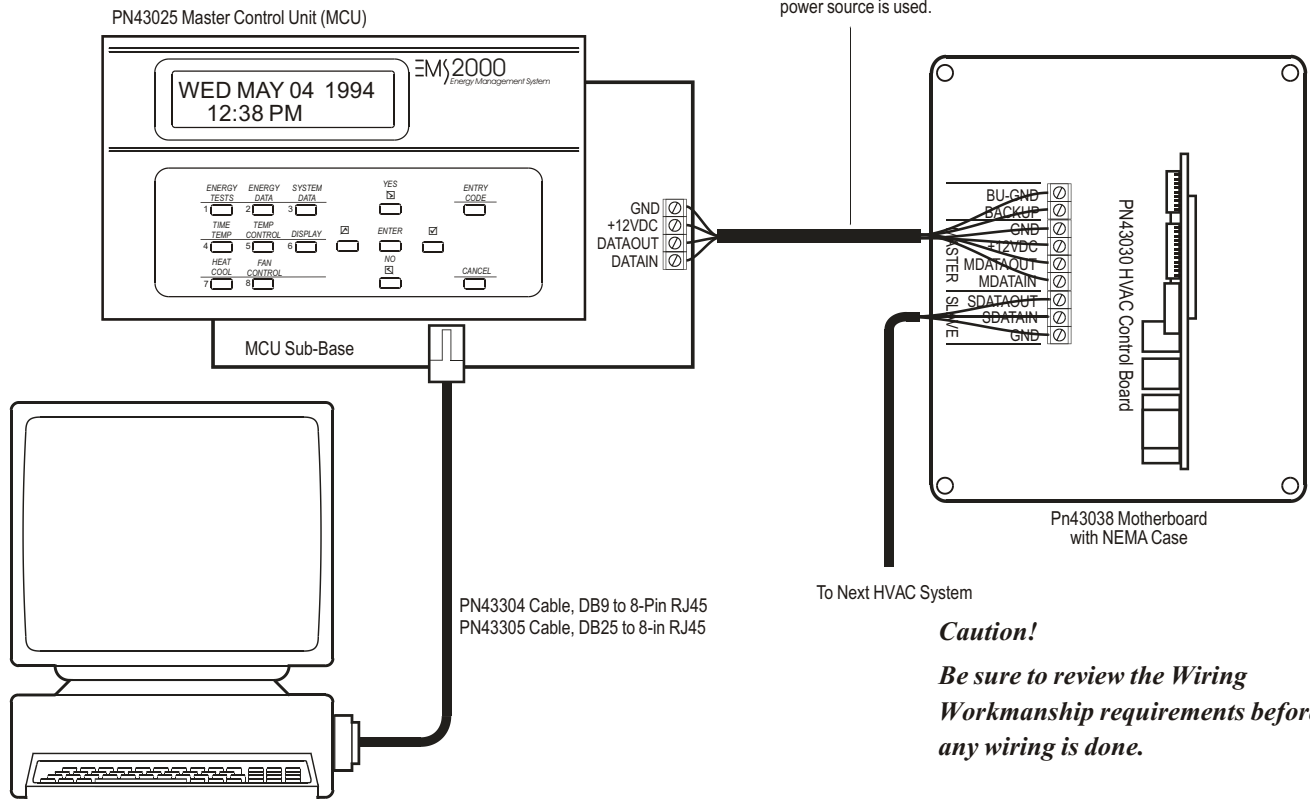

Caution!

Be sure to review the Wiring Workmanship requirements before any wiring is done.



Reference
WD03

EMS2000 Motherboard WIRING INSTRUCTIONS

Communications Wiring for the 43038 Motherboard

Using an MCU for On-Site and a PC to Provide Off-Site Control of HVAC Control Boards.

Description

An on-site Master Control Unit (MCU) and an off-site PC computer can be used to control a number of Motherboards with HVAC Control boards. The MCU is limited to 8 Motherboards, although the computer can address up to 32 units on each serial port. The computer can be used to gather energy data and generate reports remotely using a modem in the computer and a modem external to the MCU.

A 43306 Cable connects the Modem to the telephone lines and a 43307 Cable connects the Modem data output to the MCU. Standard thermostat wire can be used to connect the terminals on the MCU Sub-Base to the Motherboard at the HVAC system, provided it is less than 400 feet from the MCU. Follow the wiring instructions as shown to the right.

See Wiring Backup Power for instructions on wiring the BACKUP and BU-GND wires if a common backup power source is used.

After mechanically installing the MCU Sub-Base and installing the 43306 and 43307 Cables, connect the wires from the Sub-Base to the 43033 Motherboard as follows:

At the MCU Sub-Base	To Motherboard Terminal	Wire Color	Function
+12VDC	+12VDC	RED	+12V from HVAC Control Board
GND	GND	WHT	Signal Ground
DATA-OUT	MDATA-IN	GRN	Data from the PC Computer
DATA-IN	MDATA-OUT	BLU	Data from the Motherboard
See text.	BACKUP	YEL	Backup Power to Motherboards
See text.	BU-GND	BRN	Ground for Backup Power

The Backup terminals should be wired as shown if a common backup power source is being used. See Wiring Back-Up Power.

Wiring Materials Required

1. Thermostat Wire, 4 or 6-Conductor, AWG20.
2. Two Cables 43306 and one Cable 43307.

20 Gauge Thermostat Wire. Use 4-conductor when backup batteries are used at each control or 6-conductor if a common backup power source is used.

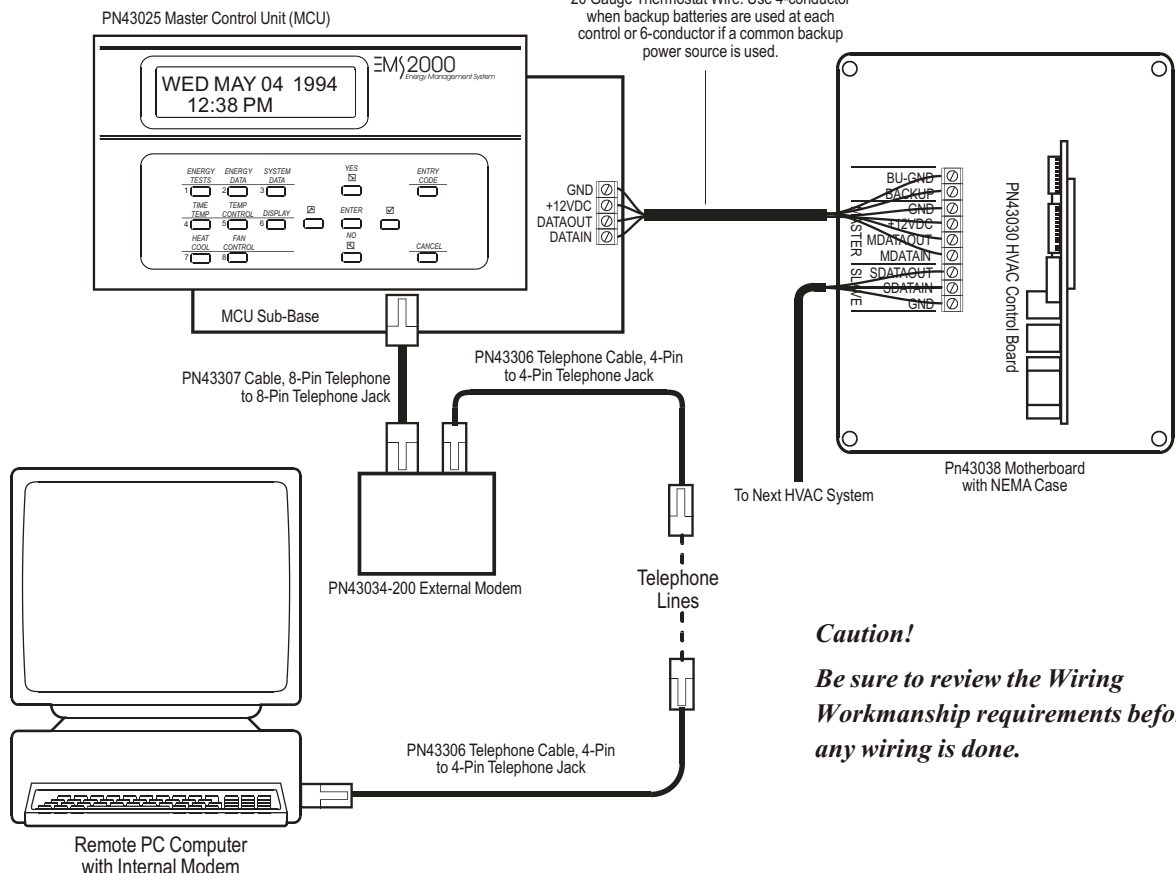

EMS2000 Motherboard WIRING INSTRUCTIONS

Communications Wiring for the 43038 Motherboard

Using an Off-Site PC to Control the HVAC Control Boards with Internal Modem.

Description

An off-site PC computer with a modem can be used to control a number of Motherboards with HVAC Control boards. The first Motherboard should have a 43034-100 Internal Modem installed. An MCU can be connected to the 4-pin MCU Test connector on the Motherboard for on-site control and testing. The MASTER PRG/RUN switch on the Motherboard determines whether the off-site PC (RUN position) or the MCU (MASTER PROG position) controls the Motherboards.

A 43306 Cable connects the Motherboard to the telephone lines and a 43308 Cable can be used to extend the short cable on the MCU. No wiring is required.

See Wiring Backup Power for instructions on wiring the BACKUP and BU-GND wires.

The MCU extension cable plugs into the 4-pin MCU TEST CONNECTOR. To select MCU operation, move the Master switch to the MASTER PROG position shown below. The Modem input and Master Data input terminals are now isolated from the Motherboards. To isolate the rest of the Motherboards, move the Slave switch to the SLAVE PROG position and you can now program the HVAC and Analog board without affecting other modules.

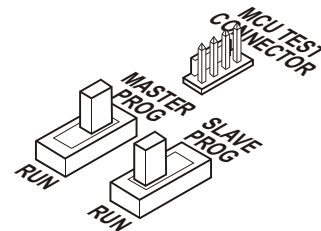

Wiring Materials Required

- Two 43306 Cables and one 43308 Cable.

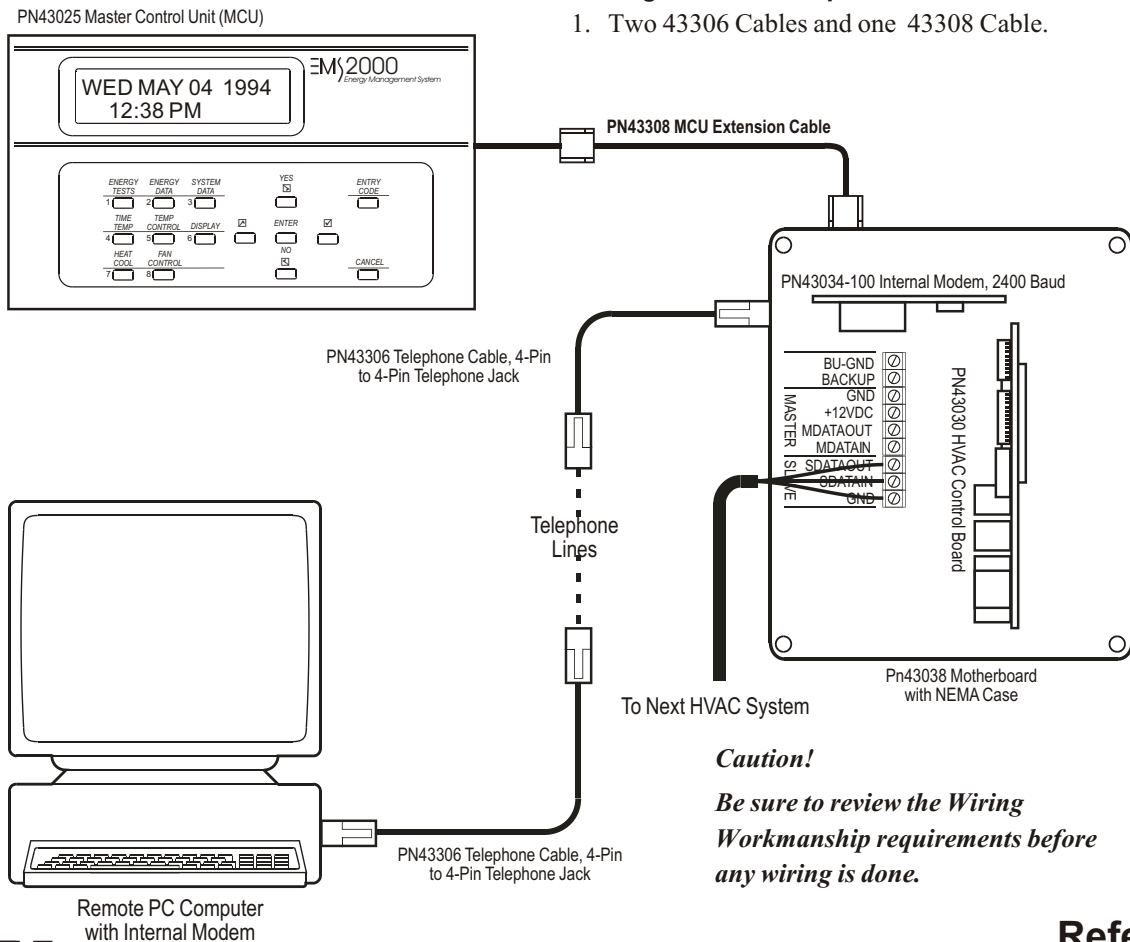

Caution!

Be sure to review the Wiring Workmanship requirements before any wiring is done.



Reference
WD05

EMS2000 Motherboard WIRING INSTRUCTIONS

Communications Wiring for the 43038 Motherboard

Motherboard to Motherboard Connections

Description

The Motherboards are connected in a daisy chain as shown below. Each HVAC Control board on the Motherboard is programmed with a different address so that only that Motherboard accepts the data being sent on the RS232 data lines and only that Motherboard responds. Certain commands can be sent to all Motherboards and only the HVAC Control board with address 01 will respond with an acknowledgement. The backup power wiring is only required if a common backup power source is being used.

After mechanically installing the NEMA cases with the Motherboards, connect the communications and backup power wires between Motherboards as follows;

At the first Motherboard	At the next Motherboard	Wire Color	Function
GND	GND	WHT	Signal Ground
SDATA-OUT	MDATA-IN	GRN	Data from the first
SDATA-IN	MDATA-OUT	BLU	Data from the next
BACKUP	BACKUP	YEL	Backup Power to Motherboards
BU-GND	BU-GND	BRN	Ground for Backup Power

The Backup terminals should be wired as shown if a common backup power source is being used. See Wiring Back-Up Power.

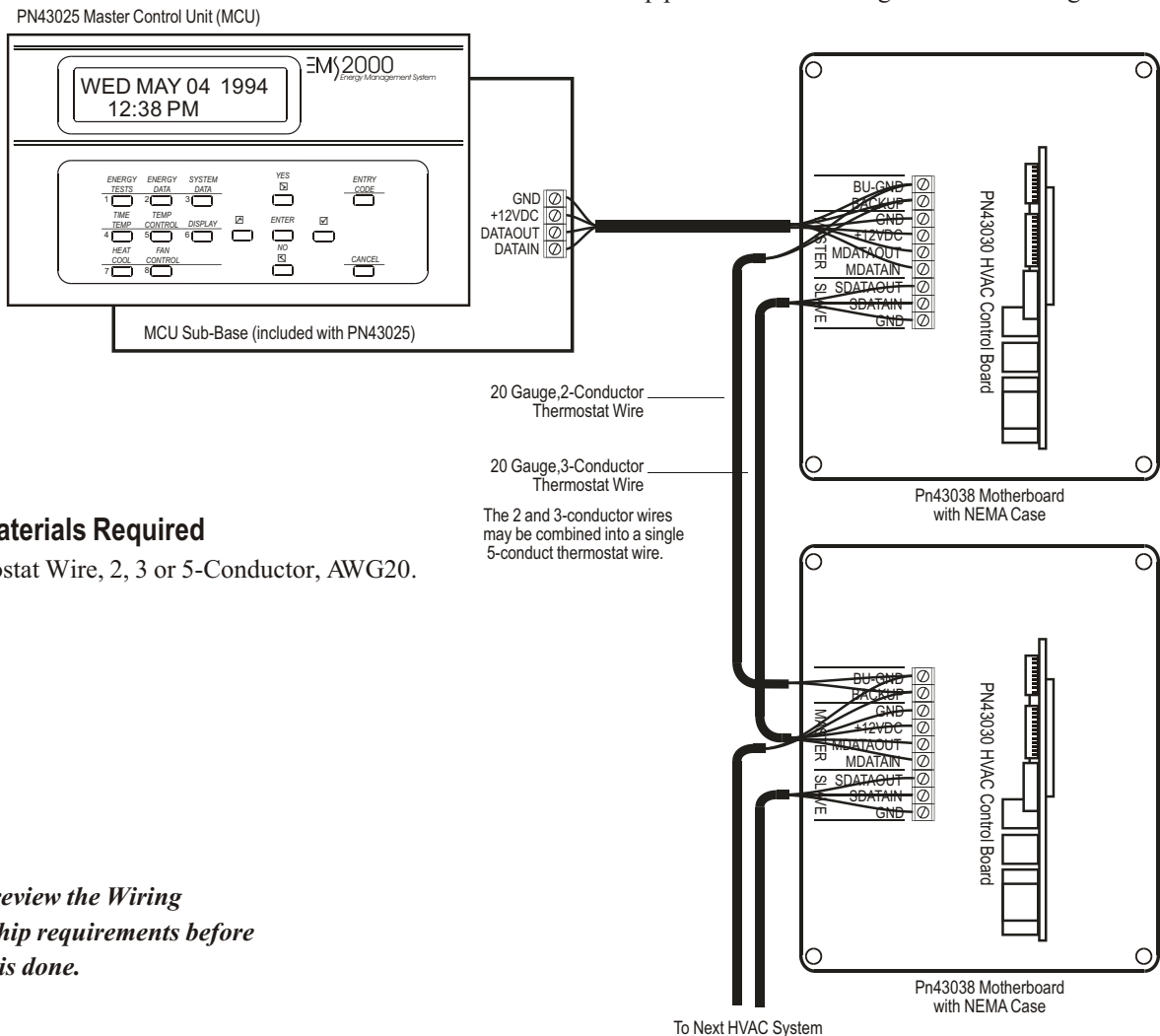

Wiring Materials Required

1. Thermostat Wire, 2, 3 or 5-Conductor, AWG20.

Caution!

Be sure to review the Wiring Workmanship requirements before any wiring is done.



EMS2000 Motherboard WIRING INSTRUCTIONS

Power Wiring for the 43038 Motherboard

Connecting 12VAC or +24VAC Power to the 43038 Motherboard.

Description

The 43038 Motherboard is available in two versions. The 43038-212 or 43038-224 Motherboard is powered by 12VAC or 24 VAC..

Motherboard 43038-212 or 43038-224

The 12or 24 VAC transformer should be installed within the high voltage area in the HVAC system, or it can be mounted externally to the system, provided it meets all applicable wiring codes. The transformer should have a minimum rating of 10VA. The 12 or 24 VAC output should be isolated from the high voltage primary.

The primary should be connected to a fused power source and the 12 or 24 VAC secondary connected to the 12VAC terminals on the Motherboard using AWG20 or larger wire.

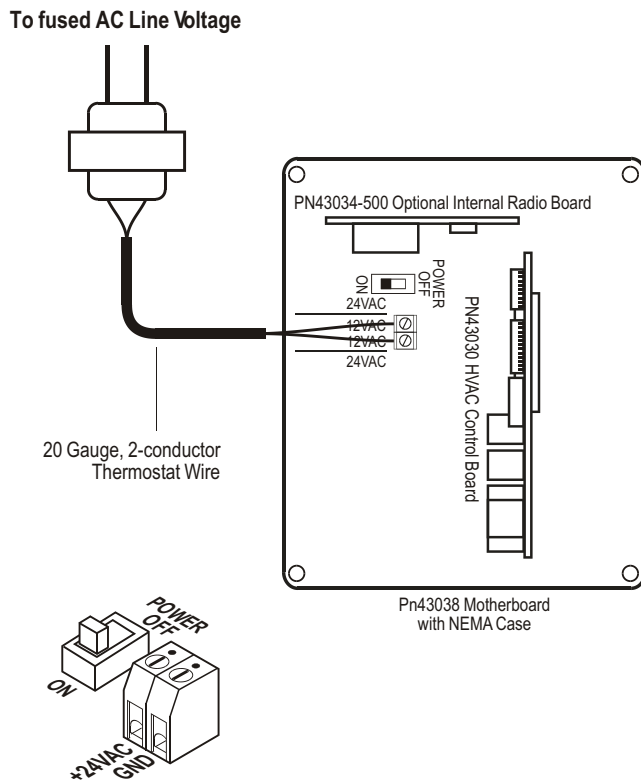

Wiring Materials Required

1. Two 43306 Cables and one 43308 Cable.

APPROVED TRANSFORMERS

Model Number	Manufacturer	Available From	Input Rating	Output Rating
43320-020	Winn	Winn	120/240VAC	12VAC,20VA

Motherboard 43038-x24

This Motherboard operates from +24VAC +/-5% supplied by the customer. Wiring for the power is shown below.

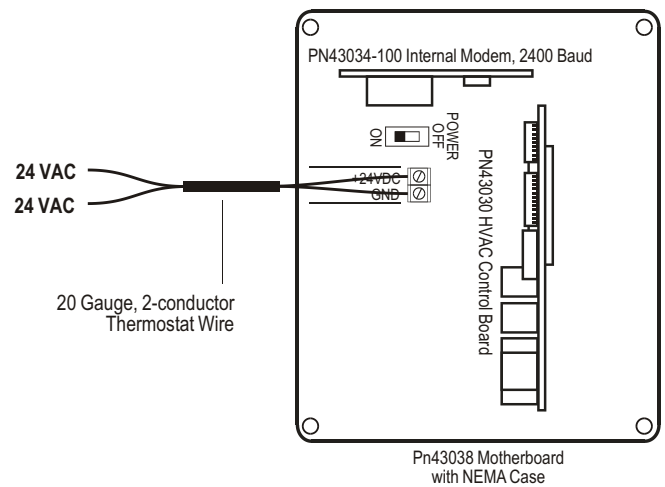

Power On/Off Switch

A switch is provided on the Motherboards for controlling power to the Modem, HVAC Control board. Whenever wiring is changed or a board removed or installed, the power should be turned off.

Caution!

Be sure to review the Wiring Workmanship requirements before any wiring is done.



EMS2000 Motherboard WIRING INSTRUCTIONS

Room Temperature Sensor Wiring for the 43038 Motherboard

Description

The Room Temperature Sensor is available in different configurations. All include a thermistor type temperature sensor, keys for adjusting the setpoint temperature and optionally a thermometer with an LCD display.

The sensor should be located on a wall where it will accurately sense the space temperature. Use the same good practices as when installing a conventional thermostat. The schematic of the Room Temperature Sensor is shown below.

Using an appropriate sized wire nut, connect the wires to the wires on the Room Temperature Sensor (RTS). Connect the corresponding wires to the 43038 Motherboard as shown below.

At the RTS	To Motherboard Terminal	Wire Color	Function
GND	GND	GRN	Signal Ground
+5VDC	+5VDC	RED	+5VDC Power from Motherboard
SNR	ROOM SNR	BLU	Thermistor Output
WRM	WRM KEY	WHT	Warmer Key
CLR	CLR KEY	YEL	Cooler Key

The GND, WRM KEY and CLR KEY wires do not have to be connected if only a temperature sensor is being used.

Wiring Materials Required

1. Thermostat Wire, 2 or 5-Conductor, AWG20.

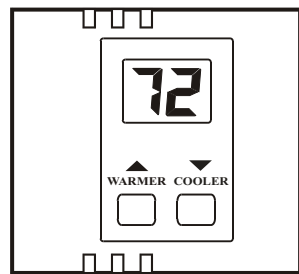
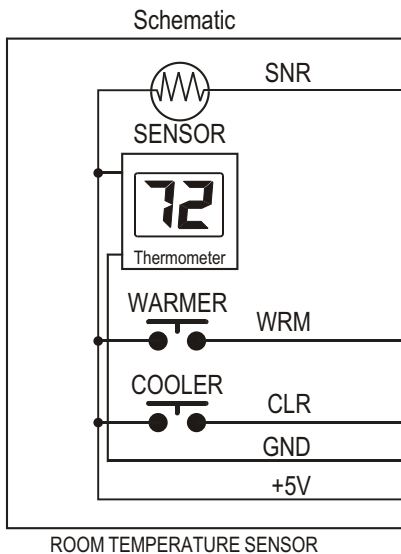

20 Gauge, 2 or 5-Conductor
Thermostat Wire

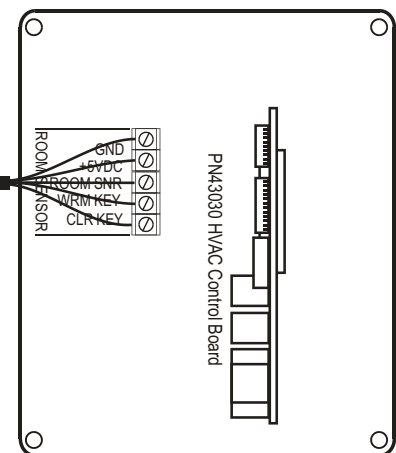

Pn43030 HVAC Control Board
Pn43038 Motherboard
with NEMA Case

Caution!

Be sure to review the Wiring Workmanship requirements before any wiring is done.



EMS2000 Motherboard WIRING INSTRUCTIONS

Supply and Roof Air Temperature Sensor Wiring for the 43038 Motherboard

Description, Supply Air Temperature Sensor

The supply air sensor should be installed so that it senses the temperature of the the HVAC unit's supply air and not the temperature of the mechanical structure. Be careful not to locate it too close to the coil or the heat exchanger.

After mechanically installing the sensor, use appropriate sized wire nuts to connect the two wires of a 2-conductor thermostat cable to the wires on the temperature sensor. Connect the corresponding wires at the 43038 Motherboard as shown below.

At the Sensor	To Motherboard Terminal	Wire Color	Function
SNR	SUPPLY SENSOR	WHT	Thermistor Output
SNR	SUPPLY SENSOR	RED	Thermistor Output

The SUPPLY SENSOR terminals are not polarized and either wire can be connected to either terminal.

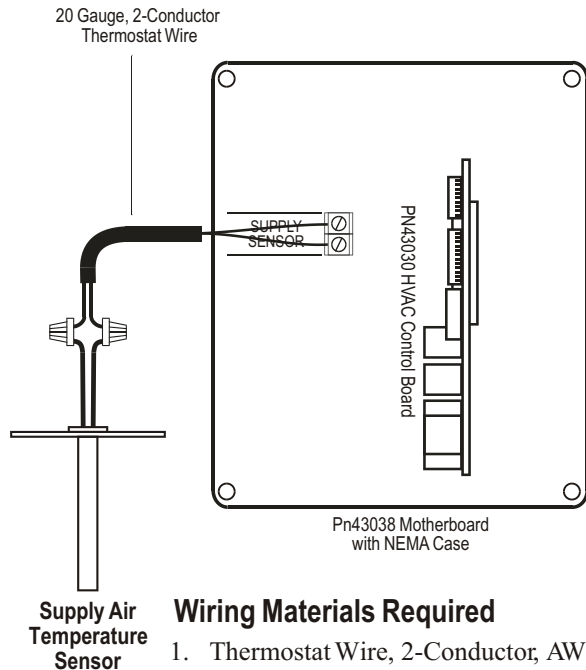

Description, Outdoor Temperature Sensor

The roof or outdoor temperature sensor should be installed so that it senses the outdoor air temperature. Be careful not to locate it in direct sunlight or on heated surfaces.

After mechanically installing the sensor, use appropriate sized wire nuts to connect the two wires of a 2-conductor thermostat cable to the wires on the temperature sensor. Connect the corresponding wires at the 43038 Motherboard as shown below.

At the Sensor	To Motherboard Terminal	Wire Color	Function
SNR	ROOF SENSOR	WHT	Thermistor Output
SNR	ROOF SENSOR	RED	Thermistor Output

The ROOF SENSOR terminals are not polarized and either wire can be connected to either terminal.

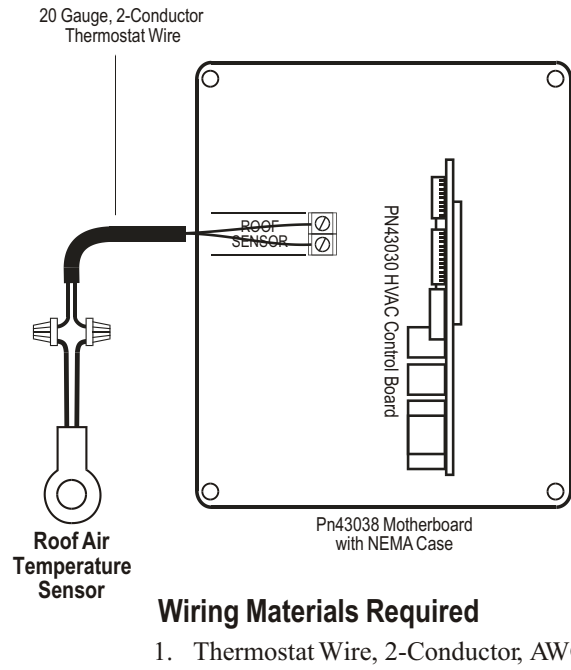

Caution!

Be sure to review the Wiring Workmanship requirements before any wiring is done.



EMS2000 Motherboard

WIRING INSTRUCTIONS

HVAC Terminal Wiring

for the 43038 Motherboard

Motherboard Terminal	Type of HVAC System Selected		
	Gas/Electric System	Heat Pump with O-Type Valve	Heat Pump with B-Type Valve
RH	<p>Provides 24VAC to the W1 Control Relay</p> <p>Connect RH to the R terminal of the heating system. Connect RH/RC to the R terminal at the HVAC system for HVAC systems with one transformer for both heating and cooling..</p>	<p>Provides 24VAC to the W1 Control Relay</p> <p>Heat Pumps have only one transformer and RH and RC should be connected together and to the R terminal at the HVAC system.</p>	<p>Provides 24VAC to the W1 Control Relay</p> <p>Heat Pumps have only one transformer and RH and RC should be connected together and to the R terminal at the HVAC system.</p>
RC	<p>Provides 24VAC to the W2,Y1, Y2, G and E Control Relays</p> <p>Connect RC to the R terminal of the cooling system. Connect RH/RC to the R terminal at the HVAC system for HVAC systems with one transformer for both heating and cooling..</p>	<p>Provides 24VAC to the W2,Y1, Y2, G and E Control Relays</p> <p>Heat Pumps have only one transformer and RH and RC should be connected together and to the R terminal at the HVAC system.</p>	<p>Provides 24VAC to the W2,Y1, Y2, G and E Control Relays</p> <p>Heat Pumps have only one transformer and RH and RC should be connected together and to the R terminal at the HVAC system.</p>
C	<p>Provides a common or return for 24VAC RH and RC and for the LEDs and filters on the Motherboard.</p> <p>Connect C terminal to the common side of the HVAC 24VAC transformer(s) in the HVAC system which is normally indicated as C or sometimes as X.</p>	<p>Provides a common or return for 24VAC RH and RC and for the LEDs and filters on the Motherboard.</p> <p>Connect C terminal to the common side of the HVAC 24VAC transformer in the HVAC system which is normally indicated as C or sometimes as X.</p>	<p>Provides a common or return for 24VAC RH and RC and for the LEDs and filters on the Motherboard.</p> <p>Connect C terminal to the common side of the HVAC 24VAC transformer in the HVAC system which is normally indicated as C or sometimes as X.</p>
W1	<p>Controls the first stage heating and will be activated (24VAC) when there is a call for first stage heating.</p> <p>Connect W1 terminal to the terminal controlling stage 1 heating which is normally indicated as W or W1.</p>	<p>Controls the O-Type Reversing Valve and will be activated (24VAC) when there is a cooling call.</p> <p>Connect W1 terminal to the terminal controlling the O-Type reversing valve which is normally indicated as O.</p>	<p>Controls the B-Type Reversing Valve and will be activated (24VAC) when there is a heating call.</p> <p>Connect W1 terminal to the terminal controlling the B-Type reversing valve which is normally indicated as B.</p>
W2	<p>Controls the second stage heating and will be activated (24VAC) when there is a call for second stage heating.</p> <p>Connect W2 terminal to the terminal controlling stage 2 heating which is normally indicated as W2.</p>	<p>Controls the second stage auxiliary heating and will be activated (24VAC) when there is a call for second stage heating.</p> <p>Connect W2 terminal to the terminal controlling stage 2 heating which is normally indicated as W2.</p>	<p>Controls the second stage auxiliary heating and will be activated (24VAC) when there is a call for second stage heating.</p> <p>Connect W2 terminal to the terminal controlling stage 2 heating which is normally indicated as W2.</p>
Y1	<p>Controls the first stage cooling and will be activated (24VAC) when there is a call for first stage cooling.</p> <p>Connect Y1 terminal to the terminal controlling the stage 1 compressor which is normally indicated as Y or Y1.</p>	<p>Controls the compressor and will be activated (24VAC) when there is a call for first stage heating or cooling.</p> <p>Connect Y1 terminal to the terminal controlling the stage 1 compressor which is normally indicated as Y or Y1.</p>	<p>Controls the compressor and will be activated (24VAC) when there is a call for first stage heating or cooling.</p> <p>Connect Y1 terminal to the terminal controlling the stage 1 compressor which is normally indicated as Y or Y1.</p>
Y2	<p>Controls the second stage cooling and will be activated (24VAC) when there is a call for second stage cooling.</p> <p>Connect Y2 terminal to the terminal controlling the stage 2 compressor which is normally indicated as Y2.</p>	<p>Controls the second stage cooling and will be activated (24VAC) when there is a call for second stage cooling.</p> <p>Connect Y2 terminal to the terminal controlling the stage 2 compressor which is normally indicated as Y2.</p>	<p>Controls the second stage cooling and will be activated (24VAC) when there is a call for second stage cooling.</p> <p>Connect Y2 terminal to the terminal controlling the stage 2 compressor which is normally indicated as Y2.</p>
G	<p>Controls the indoor fan and will be activated (24VAC) when there is a call for cooling or the fan turned on for ventilation.</p> <p>Connect G terminal to the terminal controlling the indoor fan which is normally indicated as G.</p>	<p>Controls the indoor fan and will be activated (24VAC) when there is a call for heating, cooling or the fan turned on for ventilation.</p> <p>Connect G terminal to the terminal controlling the indoor fan which is normally indicated as G.</p>	<p>Controls the indoor fan and will be activated (24VAC) when there is a call for heating, cooling or the fan turned on for ventilation.</p> <p>Connect G terminal to the terminal controlling the indoor fan which is normally indicated as G.</p>
E	<p>Controls the economizer damper and will be activated (24VAC) when there is a call for economizer cooling.</p> <p>Connect E terminal to the terminal controlling the economizer damper.</p>	<p>Controls the economizer damper and will be activated (24VAC) when there is a call for economizer cooling.</p> <p>Connect E terminal to the terminal controlling the economizer damper.</p>	<p>Controls the economizer damper and will be activated (24VAC) when there is a call for economizer cooling.</p> <p>Connect E terminal to the terminal controlling the economizer damper.</p>



EMS2000 Motherboard WIRING INSTRUCTIONS

HVAC Wiring for the 43038 Motherboard

Typical Wiring of a Gas Furnace with Electric Air Conditioning

Description

The wiring diagram below is typical of a two-stage gas/electric system.

HVAC System Wiring

At the HVAC System	To Motherboard HVAC Terminal	Wire Color	Function
R	RH and RC	RED	24VAC
C	C	BRN	24VAC Common
W1	W1	WHT	Stage 1 Heating Control
W2	W2	BLU	Stage 2 Heating Control
Y1	Y1	YEL	Stage 1 Cooling Control
Y2	Y2	ORG	Stage 2 Cooling Control
G	G	GRN	Indoor Fan Control

Wiring Materials Required

1. Multi-conductor, 20 guage thermostat wire.

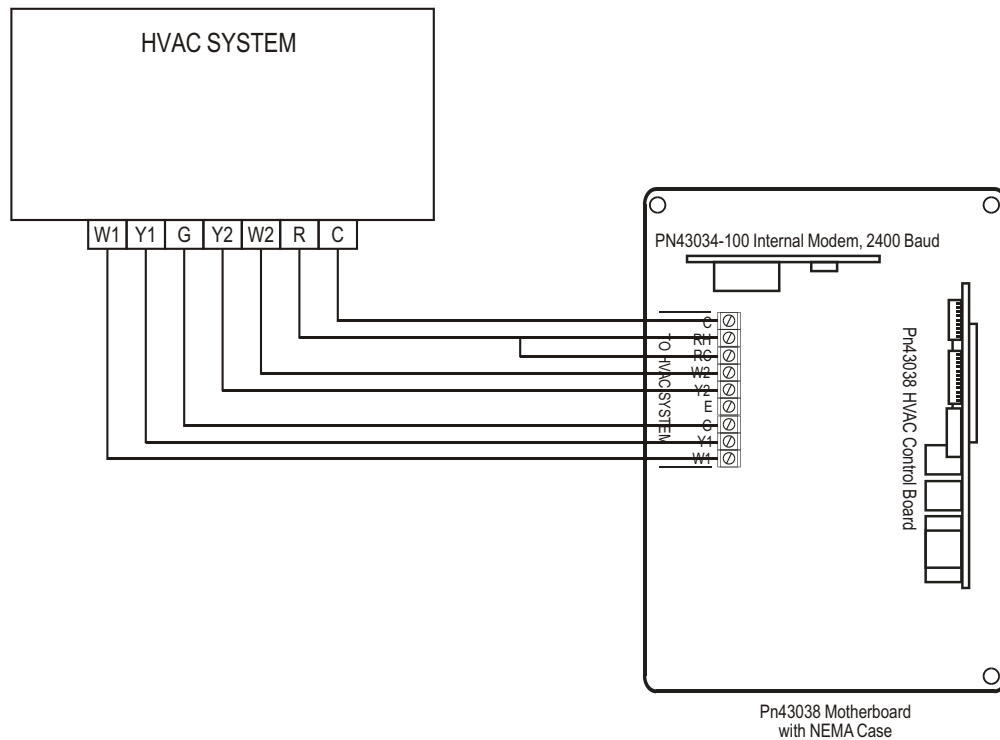

EMS2000 Motherboard WIRING INSTRUCTIONS

HVAC Wiring for the 43038 Motherboard

Typical Wiring of a Gas Furnace with Electric Air Conditioning

Description

The wiring diagram below is typical of a two-stage gas/electric system.

The E terminal at the Motherboard is used to control an add-on economizer. A relay and transformer must be added to control the economizer's motorized damper. If a line voltage motorized damper is used, the transformer is not required.

HVAC System Wiring

At the HVAC System	To Motherboard HVAC Terminal	Wire Color	Function
R	RH and RC	RED	24VAC
C	C	BRN	24VAC Common
W1	W1	WHT	Stage 1 Heating Control
W2	W2	BLU	Stage 2 Heating Control
Y1	Y1	YEL	Stage 1 Cooling Control
Y2	Y2	ORG	Stage 2 Cooling Control
G	G	GRN	Indoor Fan Control

Wiring Materials Required

1. Multi-conductor, 20 guage thermostat wire.

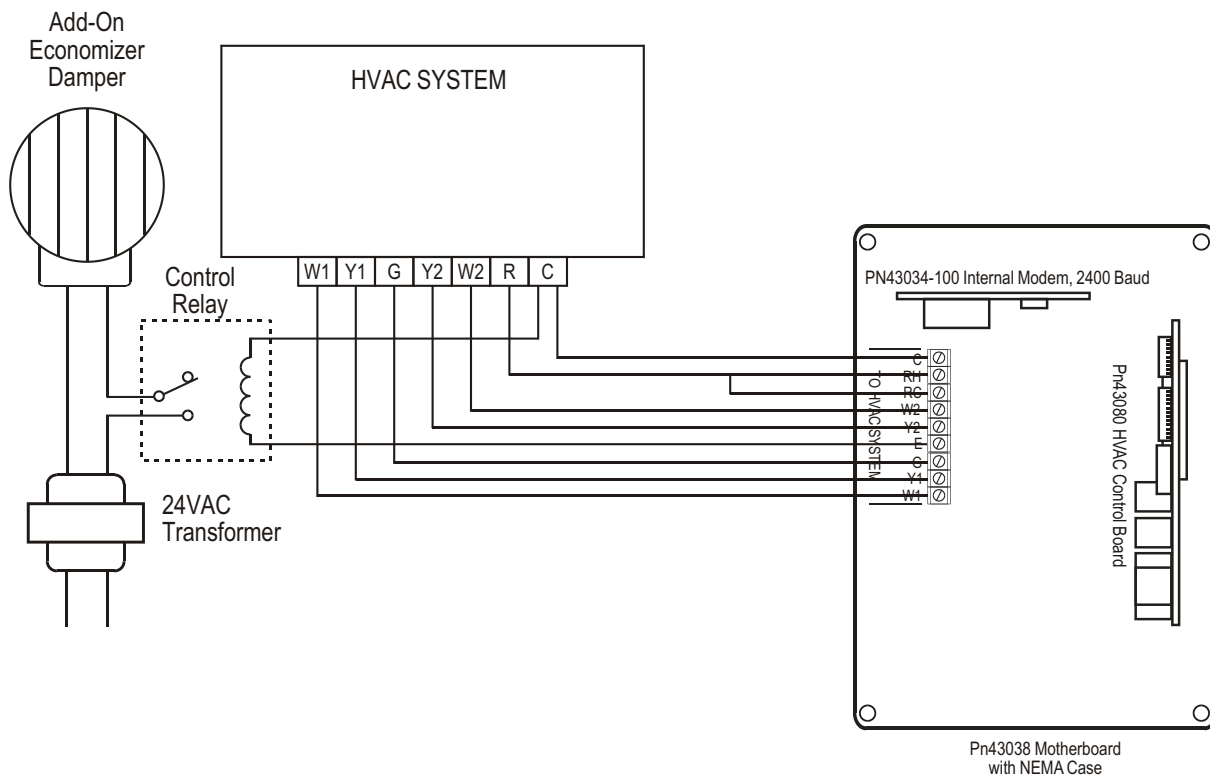

Caution!

Be sure to review the Wiring Workmanship requirements before any wiring is done.



Backup Thermostat

Reference
Wd12

EMS2000 Motherboard WIRING INSTRUCTIONS

HVAC Wiring for the 43038 Motherboard

Typical Wiring of a Single Stage Heat Pump with an O-Type Valve.

Description

The wiring diagram below is typical of a two-stage gas/electric system.

HVAC System Wiring

At the HVAC System	To Motherboard HVAC Terminal	Wire Color	Function
R	RH and RC	RED	24VAC
C	C	BRN	24VAC Common
O	W1	ORG	Reversing Valve Control
W2	W2	BLU	Stage 2 Heating Control
Y1 or Y	Y1	YEL	Stage 1 Cooling Control
G	G	GRN	Indoor Fan Control

Wiring Materials Required

1. Multi-conductor, 20 guage thermostat wire.

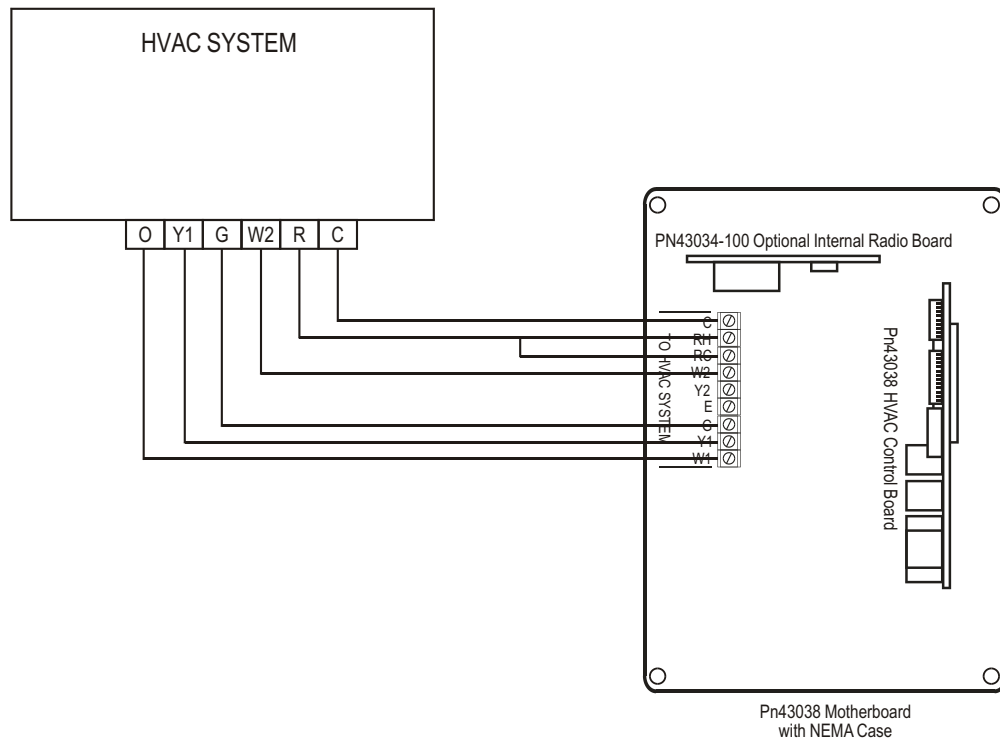

Caution!

Be sure to review the Wiring Workmanship requirements before any wiring is done.



Reference
Wd13

EMS2000 Motherboard WIRING INSTRUCTIONS

HVAC Wiring for the 43038 Motherboard

Typical Wiring of an Oil Furnace with Electric Air Conditioning

Description

The wiring diagram below is typical of an oil furnace.

The oil furnace and the air conditioning system will have separate transformers and must be wired to the RH and RC terminals.

Wiring Materials Required

1. Multi-conductor, 20 guage thermostat wire.

Caution!

Be sure to review the Wiring Workmanship requirements before any wiring is done.

HVAC System Wiring

At the A/C System	To Motherboard HVAC Terminal	Wire Color	Function
R	RC	RED	24VAC
C	C	BRN	24VAC Common
Y	Y1	YEL	Stage 1 Cooling Control
G	G	GRN	Indoor Fan Control

HVAC System Wiring

At the A/C System	To Motherboard HVAC Terminal	Wire Color	Function
T	RH	ORG	24VAC
T	W1	BLU	24VAC Common

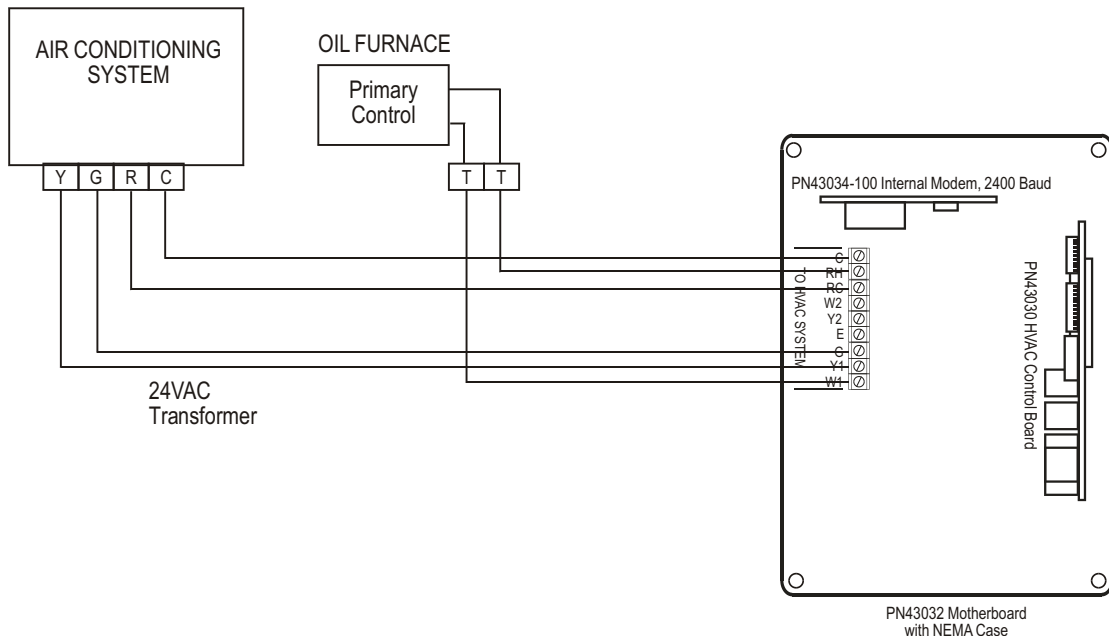

EMS2000 Motherboard WIRING INSTRUCTIONS

Backup Power Supply Wiring for the 43038 Motherboard

A Single Backup Power Supply Can Be Used To Provide Backup Power to a Number of Motherboards

Description

The Motherboards are connected in a daisy chain as shown below. Each HVAC Control board and Analog/Digital Monitor board on the Motherboard is programmed with a different address so that only that Motherboard accepts the data being sent on the RS232 data lines and only that Motherboard responds. Certain commands can be sent to all Motherboards and only the HVAC Control board with address 01 will respond. The backup power wiring is only required if a common backup power source is being used.

After mechanically installing the NEMA cases with the Motherboards, connect the communications and backup power wires between Motherboards as follows;

At the first Motherboard	At the next Motherboard	Wire Color	Function
GND	GND	WHT	Signal Ground
SDATA-OUT	MDATA-IN	GRN	Data from the first
SDATA-IN	MDATA-OUT	BLU	Data from the next
BACKUP	BACKUP	YEL	Backup Power to Motherboards
BU-GND	BU-GND	BRN	Ground for Backup Power

The Backup terminals should be wired as shown if a common backup power source is being used. See Wiring Back-Up Power.

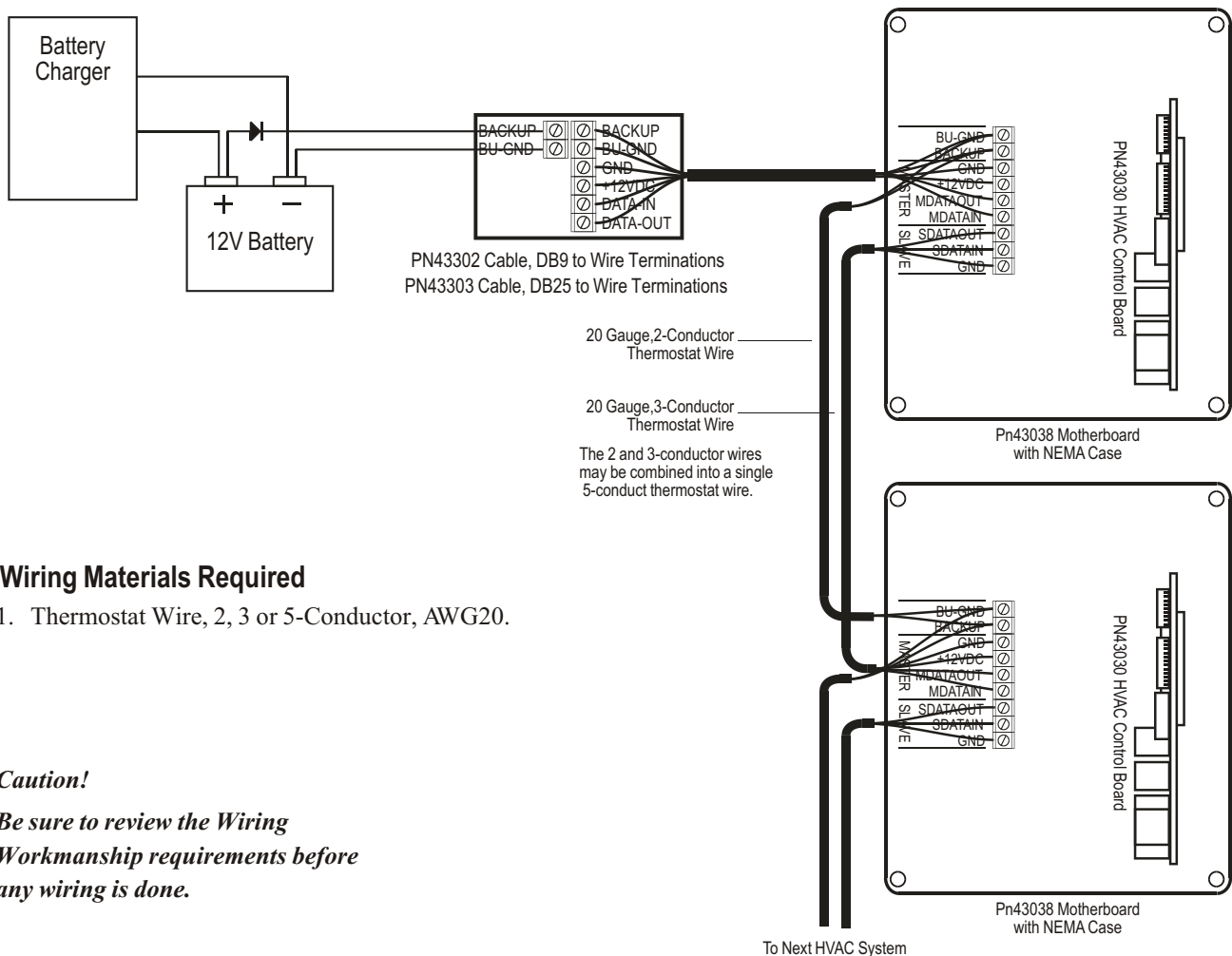

Wiring Materials Required

1. Thermostat Wire, 2, 3 or 5-Conductor, AWG20.

Caution!

Be sure to review the Wiring Workmanship requirements before any wiring is done.



Safety First

Before you perform any wiring be sure you turn Off the power breaker for the system. Failure to do so can result in personal injury and damage to the EMS2000 controls.

Local Electrical Codes

All wiring should meet al applicable electrical codes including any permit requirements.

Professional Installers

Only professional, experienced and qualified technicians should install these controls.

Approved Materials

Where applicable, only UL approved wire and supplies shall be used in the installation of these controls. Use only the size and type wire specified in the Wiring Diagrams.

Stripping and Installing Wires

The insulation on wires that are installed in the terminals on the Motherboards should be stripped about 1/4-inch being careful not to damage the conductor.

Insert the stripped conductor into the terminal and secure it with the screw. Always check that the wire is secure by gently tugging on it.

Insulation Damage Cause Shorts

The insulation on wires can be cut by sharp sheet metal and cause the conductor to short to earth ground. This provides a path for electrical damage during lightning strikes and can cause damage to the equipment.

Securing the NEMA Enclosure

The NEMA enclosure should be secured so that it cannot be damaged by technicians on the roof or be damaged by vibration. An unsecured NEMA enclosure can pose a personal hazard and potential damage to the equipment.



Winn Energy Controls, Inc.

2637 Ariane Drive

San Diego, CA 92117

Tel: (800) 770-2828

Tel: (858) 274-1330

Fax: (858) 274-1362

Web: www.winnenergy.com

Email: sales@winnenergy.com