



ADRES

**Automated Demand Response
and Energy Savings Generator
Control System**

**Installation Manual for
Kohler Generator with DEC 3 +
Control Interface**

Version 1.10



Winn Energy Controls, Inc.

Section	Description	Page
1.0	Installation Guide for the ADRES Kohler Generator Controller	
	Introduction	1 - 01
	Compatible Components	1 - 02
	Communication Board Features	1 - 03
	Relay IO Board Features	1 - 04
	Installation Overview	1 - 05
	Installation Procedures	1 - 06
	Startup and Commissioning Procedures	1 - 12
2.0	Wiring Diagrams	
	Power Supply Wiring to the Kohler Generator Main Board	2 - 01
	RS485 Communication from ADRES Comm Board to Kohler Generator	2 - 02
	ADRES Relay IO Board Start / Stop Signal Wiring (Optional)	2 - 03
	Kohler DEC 3 + Wiring Drawing	2 - 04
	Wiring Workmanship Standard	2 - 05

ADRES Generator Control INSTALLATION MANUAL

Introduction to the ADRES Control

Introduction

This manual describes the installation and wiring of the ADRES Generator control module series which are supplied in NEMA 4X type UL approved electrical enclosure. The 66200 Communication board can be powered by 12 to 24 VAC or 12 to 24 VDC. The 66200 Communication Board has four two row headers that receive an optional plug-in Relay Input / Output board 68200. The 66200 board also will receive an optional plug-in Cellular modem board (69100) and local wireless RF LAN radio board (61100). The part numbers of compatible boards are shown in Table 1.

Table 1	12-24 VAC / VDC
HVAC Communication Board	66200-100
Communication Board	66200-400
Relay IO Board, DEC 3	68200-100
Relay IO Board, DEC 3+	68200-200
Relay IO Board, DEC 3000	68200-200
Cellular Modem, Winn Wireless	69100-100
Cellular LTE Modem, Winn Wireless	70100-100
Local Wireless RF Mesh Radio	61100-100

Table 1. Part numbers for compatible Components.

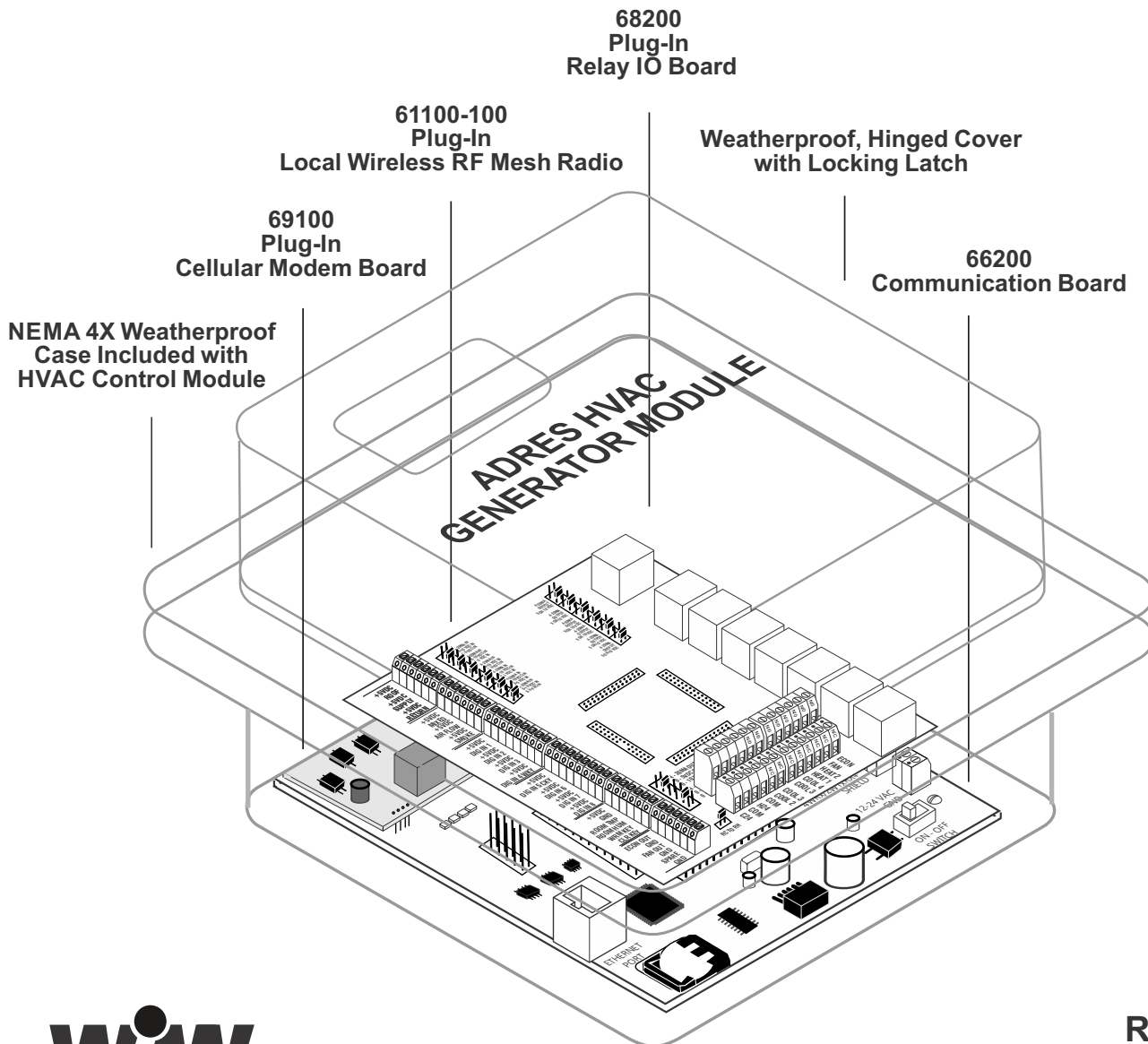

Reference
IG 01

Compatible Components

The 68200 Relay IO board plugs on to the Communication board and provides the wiring interface to the Kohler Generator DEC 3 Control. The Relay IO board and controls and monitors any Kohler generator with the DEC 3 Control.

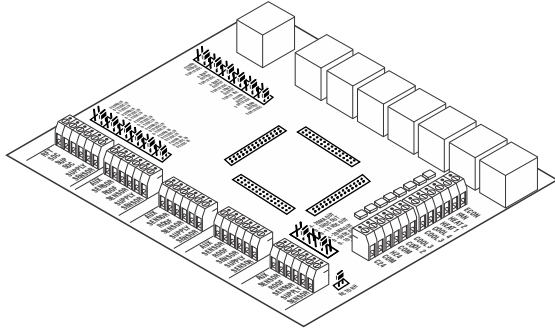

68200-x00
Relay IO Board
for Kohler DEC 3

69100-100 Plug-In Cellular WAN Modem

The 69100-100 Plug-In Cellular 2G Modem provides a private (VPN) and secure Internet wide area network (WAN) connection to the ADRES controls. The WAN Cellular Modem allows the ADRES controls to be monitored and controlled from a remote Server through the secure Internet Web browser software interface.

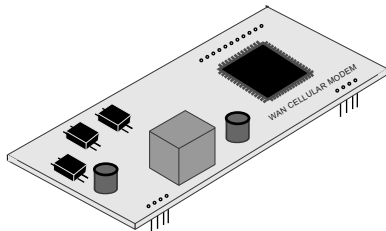

70100-100 Plug-In Cellular LTE CAT M WAN Modem

The 70100-100 Plug-In Cellular LTE CAT M cyber secure Modem provides a private (VPN) and DOD cyber-secure Internet wide area network (WAN) connection to the ADRES controls. The LTE WAN Cellular Modem allows the ADRES controls to be monitored and controlled from a remote Server through the secure Internet Web browser software interface.

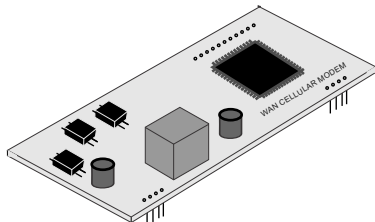

Kohler Modbus Interfaces

Kohler generator DEC 3 + Communication Module must be present or installed to allow the ADRES to communicate using Modbus protocol to the Kohler DEC 3+ control system.

GM32644-S

The P/N GM32644-S Kohler Modbus Communication Kit includes the communication board, two ribbon cables, Qty 3 board standoff attachment hardware and install guide.

61100-100 Optional Plug-In Local LAN Radio

The 61100-100 Plug-In Local Radio Modem provides the wireless communication network between each ADRES module within the building and the Cellular Modem connection. The LAN Radio modem allows the ADRES controls to communicate locally between themselves and the Cellular modem.

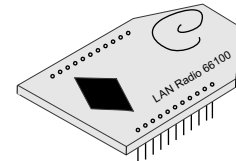

ADRES Generator Control INSTALLATION MANUAL

ADRES Communication Board P/N 66200 Features

Communication Board P/N 66200 Features

- ① **Replaceable Clock Battery**
Replaceable Clock Battery to maintain Day / Date / Time with loss of normal power.
- ② **Ethernet Port (RJ45)**
Optional Ethernet Port (RJ 45) for Internet access through Cellular modem.
- ③ **Non Volatile Memory**
Non volatile memory for up to three months of all program settings, historical performance and energy / demand consumption data.
- ④ **Plug-In Cellular Modem Board**
Plug-in Cellular WAN modem to provide ADRES system access to remote server, OpenADR2.0 and web browser software interface.
- ⑤ **LED Status Lights**
LED status lights to indicate system running and operational status.
- ⑥ **Plug-In Local Wireless Radio Board**
Plug-in wireless local area network radio to provide on-site communication between ADRES modules.
- ⑦ **RS 232 Port (DB 9)**
Jumper selectable RS 232 serial port through the DB 9 connector. Typically used for local programming through PC with EnergyPro software.
- ⑧ **USB Port**
USB port typically used for local programming through PC with EnergyPro software.
- ⑨ **RS 485 Port (2 Wire or 4-Wire)**
Terminal board to land optional hardwired RS 485 communication between ADRES control modules.
- ⑩ **12 to 24 VAC or VDC Power Terminal Board**
Terminal board to land the external 12 - 24 VAC or 12 - 24 VDC power supply.
- ⑪ **Power Switch On / Off**
Power Switch to turn On or Off the power to the ADRES HVAC Control Module.

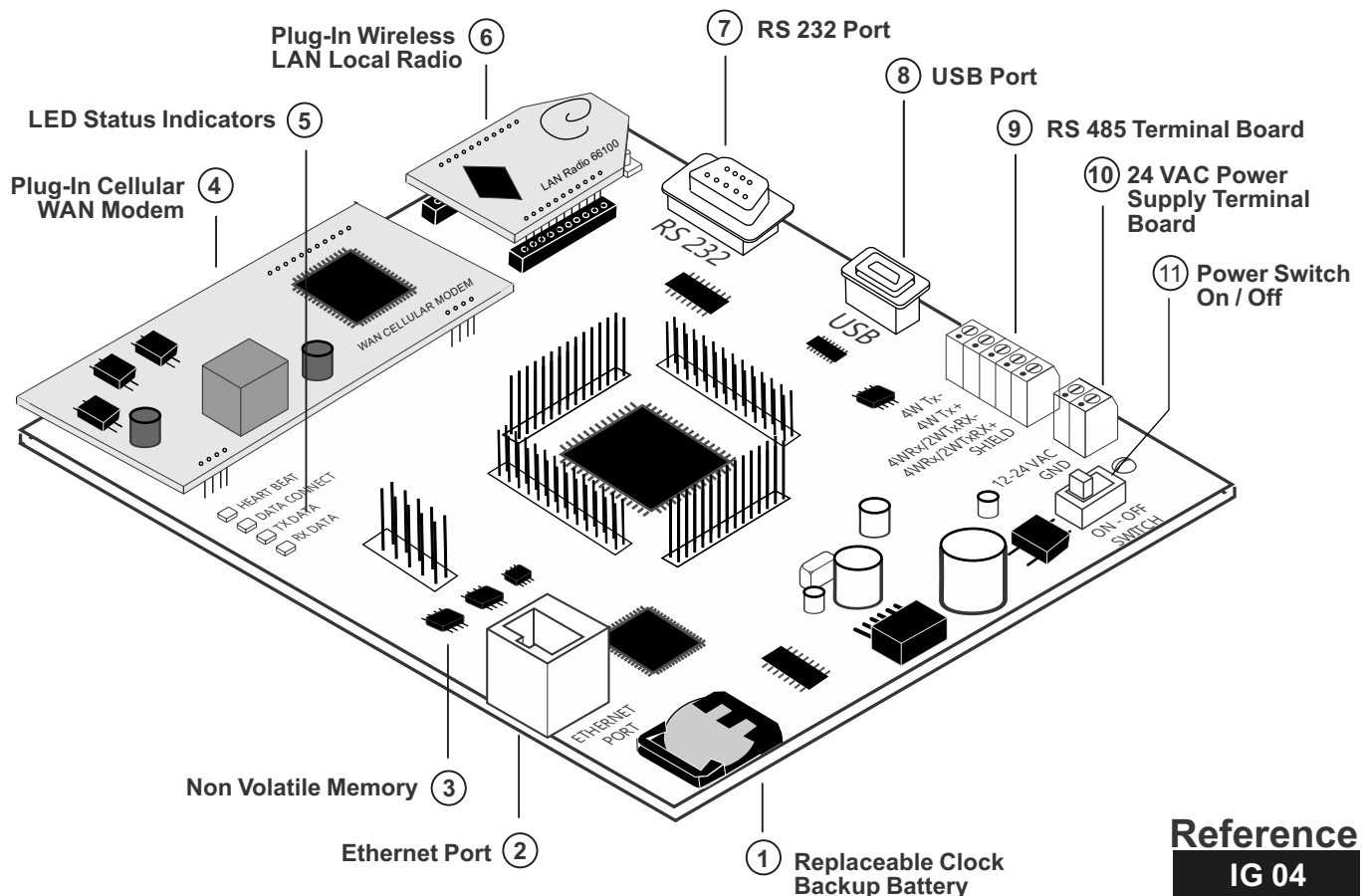

**Reference
IG 04**

Relay IO Board P/N 68200 Features

- ① **Analog Inputs**
Analog sensor inputs including temperature, pressure, flow, vibration, etc. These inputs can also be used as digital inputs.
- ② **Analog Input Sensor Selector Jumpers**
Select by Jumper from 4-20 ma, 0-5 VDC or 0-10 VDC sensor input. No jumper for 0-5 VDC sensor.
- ③ **Digital Inputs Terminal Board**
Three digital pulse counting inputs for sub-metering.
- ④ **Analog Sensor Voltage or Current Jumpers**
Analog sensor output current or voltage select jumpers. Select 4-24 ma for current sensor or 5 or 10 VDC for voltage sensor.
- ⑤ **Room Temperature Sensor Inputs**
Terminal board for room temperature sensor inputs.
- ⑥ **Analog Outputs**
Analog outputs to control variable and or modulating signals (0-5 VDC, 0-10 VDC or 4-20 ma).
- ⑦ **Analog Output Selection Jumpers**
The Analog Output selection jumpers are used to select the output signal desired, 4-20 ma current, 0-5 VDC or 0-10 VDC voltage.
- ⑧ **RC to RH Jumper**
Jumper RC to RH when the unit has only a single control transformer. Default is jumpered.
- ⑨ **Generator Unit 24 VDC Battery Power**
Terminal board to land the 24 VDC Battery power supply from the Generator.
- ⑩ **LED Lights Track Relay Output Status**
Individual LED lights track each relay output status. Green is off and Red is On.
- ⑪ **Relay Outputs to Generator**
Terminal board to land the ADRES control output relays to Generator Start and Stop contacts.

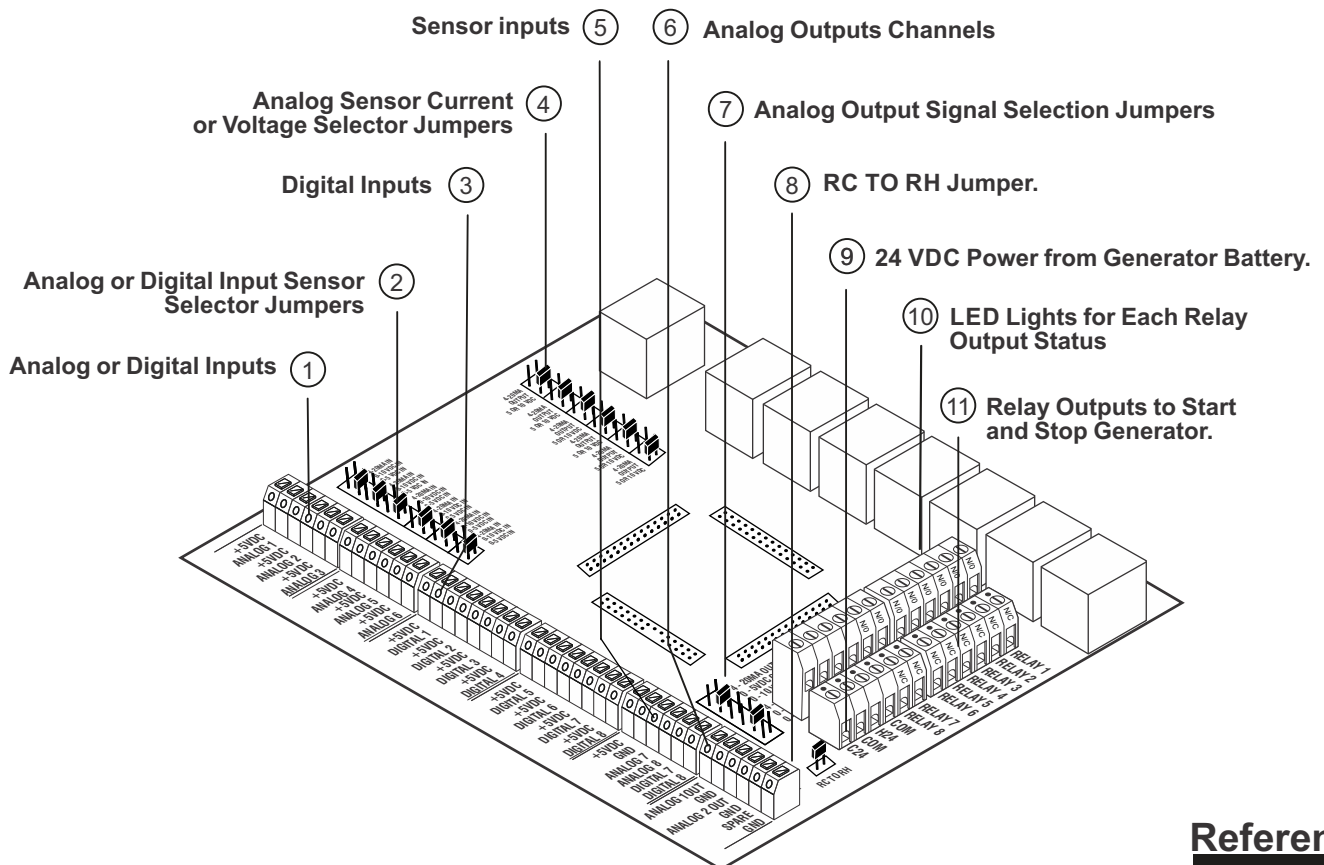

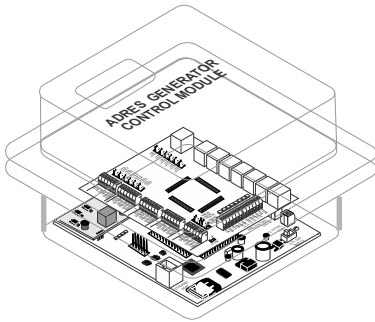

One ADRES Generator Control Module is required for each individual Generator to be monitored and controlled. The ADRES control module can be programmed to operate with most any generator make, model or size. The ADRES module is programmed remotely through the WAN Cellular modem or locally using a PC computer via either a USB or RS232 port.

Once programmed, the operating parameters are stored in non-volatile memory (unaffected by power outages) and controls the Generator independently. All data is stored in the control module and can be accessed via the remote server using the Internet web browser software interface.

Compatible Systems

The ADRES Generator control module can be installed, configured and programmed to monitor, control, and alarm a backup Generator and optionally its Automatic Transfer Switch (ATS).

Remote Annunciator Interface

Older Generators that do not have communication interfaces available to allow the ADRES control to directly communicate with the Generator to monitor the Generator performance and alarms must use the Optional ADRES Relay IO board P/N 68200-100 to wire the ADRES Analog and Digital inputs to the remote Annunciator Digital outputs.

A Kohler DEC 3 model Generator is an example of this type of interface. See page 2-04 for Wiring Diagram of DEC 3 model.

Communication to Generator

The preferred interface between the ADRES Generator control and the Generator is a hard-wired RS-485 communication link. The ADRES will continually communicate with the Generator to read its performance and alarm conditions and relay these to the EPWeb interface for display and trending.

A separate hard-wired connection should be wired between the ADRES and Generator for Start and Stop control.

Communication Wiring

Wire the ADRES Generator control from its RS-485 port to the Generator RS-485 port according to the wiring diagram.

Optionally, use the Ethernet port from the ADRES to the Generator control Ethernet port. Again, refer to the individual wiring diagram for the Make and Model of Generator being connected.

Generator Start / Stop Wiring

The preferred method for the ADRES Generator control to Start and Stop the generator is to hard-wire the ADRES Control to the remote start / stop dry contact interface provided by the Generator. This typically is a single dry contact on the Generator control terminal board that if jumpered (shorted) will start and run the generator and when opened will stop the generator. Use an 18 Gauge twisted pair shielded cable between the ADRES Control and the Generator control.

ADRES Power Supply Wiring

The ADRES control should be wired to the battery of the Generator (12-24 VDC) to provide the power supply to the control module.

The ADRES has a small replaceable fuse on the Comm board for its protection.

Mechanical Installation

The ADRES Generator control module is installed on the outside of a Generator enclosure enclosure using four sheet metal screws. The control module should be positioned high enough so that it is not subject to water from plugged drains or rain damage.

The ADRES Generator control module should be mounted on a non removable panel of the enclosure adjacent to the Generator Control Enclosure. This is typically on the Generator itself within the enclosure. There is typically both a 12-24 VDC power supply as well as the terminal board or plug in port for communication (RS-485 or Ethernet) and terminal board for monitoring the individual digital outputs for warning and alarms.

Single or multiple "seal-tite" conduit runs can be made between the ADRES control module and the Generator control enclosure. A separate 18 Gauge or larger 2-conductor shielded cable should be run for power supply. A multi-conductor 16 channel shielded should be run for digital signal

Kohler Generator ADRES Control Installation Procedures for DEC 3 +

1. Identify the Make, Model, Serial Number and Control type for the Generator that the ADRES Generator control installed.



Figure 1 Make, Model and Serial Number Tag

- a. Dec 3 + is identified by the black control enclosure mounted on top of the Generator proper inside the Outdoor Enclosure and the control panel face and annunciator LEDs is made available by opening the door on the back of the Enclosure.
2. Take the quantity (8) four screws out of each side of the metal control enclosure on top of the generator to view the actual printed circuit boards.



Remove the four screws from each side and lift cover to view circuit boards and wiring.

Figure 2 Control Enclosure Lid Removal

- a. Note the main circuit board part number to identify the Kohler control type and confirm it is a DEC 3 + module.

1. Take a new Kohler Modbus control kit (P/N GM32644-S) to the job site to support the installation.
2. If the Kohler Modbus board is installed, proceed to x.
3. If the Kohler Modbus board is not installed:
 - a. Place the Generator into the Off / Reset position on the Main Control board.



Place Switch in Off / Reset position. Buzzer will sound.

Figure 1 Control Panel Annunciator Lights and Control Switches

Note the alarm buzzer will sound and continue to sound while the Generator is in the off mode.

- b. Identify the middle fuse holder (note three fuse holders are mounted in a vertical configuration) and insert a short flat head screwdriver to turn the middle fuse counter clock wise to release the spring loaded fuse. The flashing lights and buzzer will turn off.

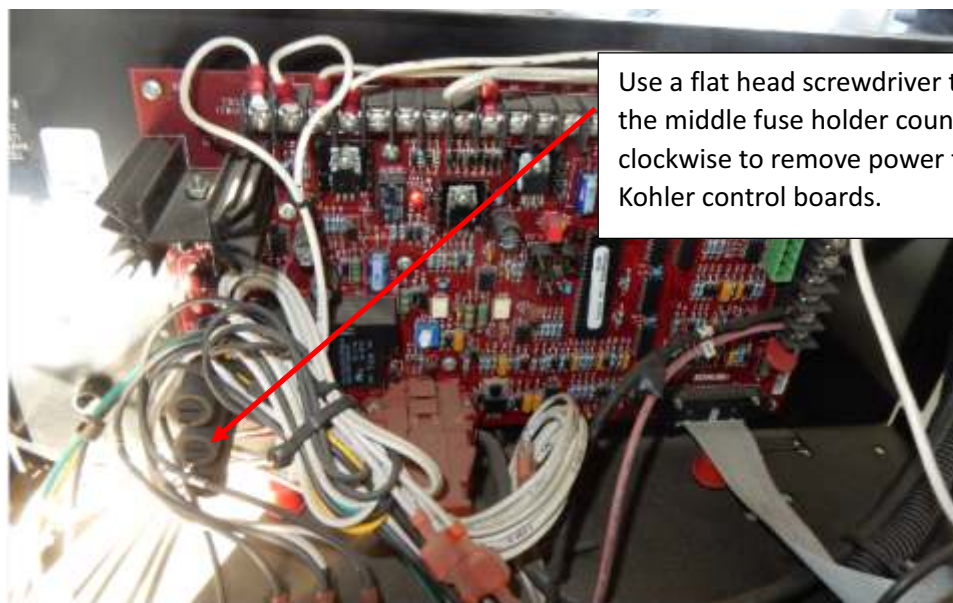

Use a flat head screwdriver to turn the middle fuse holder counter clockwise to remove power from Kohler control boards.

1. Determine if the Kohler Modbus interface board is mounted, wired and available to support the ADRES control installation.



Main board to Annunciator board ribbon cable. No Modbus communication board install.

Figure 1 Main Control Board Annunciator and Communication board ribbon cable.

- a. See attached photo showing the Kohler Modbus communication board.

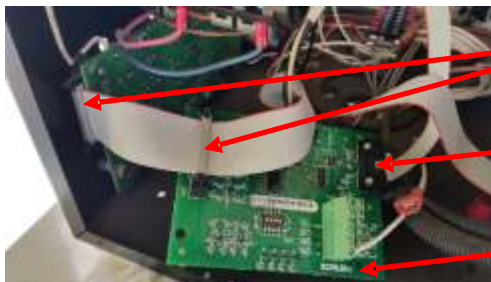

Install new ribbon cable that came in kit as shown. Remove original and save.

Install new cable and connector between communication board and main board.

Kohler Communication Module
P/N GM32644-S.

- b. Once the power is off on the control, mount the Kohler Modbus control board using the quantity (3) three screw on the stand offs provided in the kit. You will first have to remove the quantity (3) nuts holding the annunciator board first.
- c. Remove the Ribbon cable from the annunciator board and Main control board. Press the outside of the cable tabs to release the cable ends.

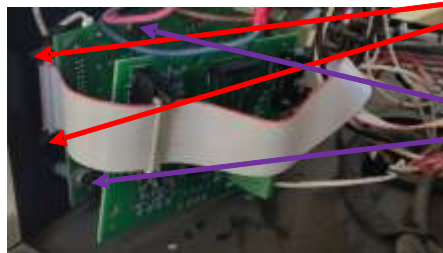

Press outside of Tabs to release ribbon cable connectors.

Remove Qty 3 nuts holding annunciator board and install Qty 3 standoff and mount communication board.

Figure 2 Communication board to Annunciator Board Mount and Cable Connections

- a. Mount the Kohler Modbus board as shown in above photo and attach the quantity (3) nuts removed to secure the new board on top of the annunciator board.
- b. Install the ribbon cable that came in the kit to the three Modbus, annunciator and main boards. Note the orientation of the cable in the Figure 5 above.
- c. Install the second cable from the main board to the Modbus module.

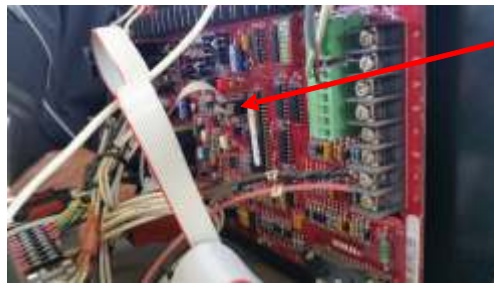

Install the second new ribbon cable from Communication board to Main board. Note the orientation.

Figure 1 Second Ribbon Cable to Communication Board

- d. Adjust the Modbus addressing dipswitch (SW 1) to match the following configuration. Switch one is located on top and switch 8 is located at the bottom. Looking at the switch position, Open is IN or down on the left of each switch and Closed is IN or down on the right of each switch.

- Switch 1 - CLOSED position
- Switch 2 - CLOSED position
- Switch 3 - OPEN position
- Switch 4 - OPEN position
- Switch 5 - CLOSED position
- Switch 6 - OPEN position
- Switch 7 - OPEN position
- Switch 8 - OPEN position

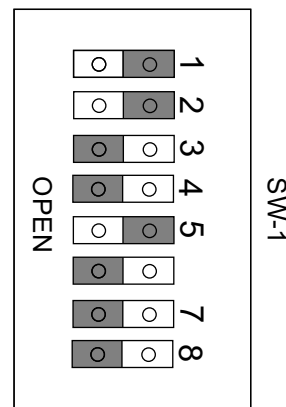

See attached photo below showing correct configuration.



Figure 1 Dipswitch SW 1 Settings for Communication board with Annunciator Board.

- a. Mount the ADRES Control NEMA case on the outside of the Generator enclosure on a non-removal panel. Install a $\frac{3}{4}$ inch diameter Seal-Tite connector between the bottom of the ADRES NEMA case and the Generator enclosure to route the quantity 3 cables to the Kohler controller boards. Route the cables under the generator cover using the existing conduit to the controller boards.



Figure 2 ADRES NEMA Case Recommended Installation Location.

-
- a. Wire the 2- conductor twisted shielded power supply cable from the ADREScontrol Terminal Board J1 +12-24 VDC on top terminal and Ground on bottom terminal of the removable plug-in connector to the ADRES control. The other end of the cable lands on the Kohler main board TB 1 across the top. The +24 VDC is on terminal 42A and GND is on terminal 2. (Note Wiring Diagram WD – 01)
 - b. Wire a second 2-conductor twisted shielded cable between the ADRESCommunication board on terminal board J5 Terminal 2WTxRx+ and 2WTxRx- (RS-485) and the other end to the TB2 terminal pin TB2-3 and TB2-4 (Note Wiring Diagram WD - 03)
 - c. Wire the third 2-conductor twisted shielded Generator Start / Stop cable between the ADRES Relay IO board on Relay 1 N/O terminals and the +C24 terminal and the other end to the TB2 terminal pin TB2-3 and TB2-4 (Note Wiring Diagram WD - 04)
 - d. Secure the cable runs from the ADRES Controller to the existing wiring cables and conduits.
 - e. Review the board installations and connections.
 - f. Re-energize the power to the control by pushing in and turning clockwise the middle fuse holder.
 - g. Confirm the power is on the front control panel and the buzzer is ringing.
 - h. Place the Generator in Automatic with the three position switch below and annunciator light panel.



Generator Run – Off/Reset - Auto Switch
Move switch to right in AUTO mode.

Figure 1 Control Mode Switch. Shown in Off Position

Startup and Commissioning

1. Turn the power On/Off switch in the ADRES Controller to the ON position. On is moving the switch to the left or toward the Ethernet port.
2. Confirm the ADRES red heartbeat light is blinking on and off.
3. Logon to the ADRES Controller at:

<http://energypro.winnenergy.com/epweb4>

4. View the real-time performance returned from the Kohler Generator. On the main Generator page, select the Generator setup done prior to the field install. Press the Update Readings on the main page and confirm the ADRES returns the performance points and current generator status.
5. Confirm the ADRES Generator Status matches the Kohler Generator annunciator panel.
6. Obtain permission start the generator from the local Manager and others. Start the Generator through the EPWeb interface while the technician is still local to the Generator. Press the Start in the EPWeb interface and confirm the ADRES Relay 1 is closed, the Relay 1 LED status light change to Red when the Relay is closed. The Generator should start immediately when the Relay 1 LED on the ADRES changes from Red to Green.
7. While the generator is running, wait for the ADRES to report the Generator Running status / alarm on the EPWeb interface.
8. Press the Generator Stop button in the EPWeb page to send the command to the Generator to stop the Generator running.

-
1. The ADRES should also report a final generator status to clear the Alarm indication and show the generator is off and back to normal Ready to Run status.
 2. In the EPWeb Unit Setup page, confirm all the Make, Model, and Part Numbers to make this information available for future maintenance.
 3. Return the Generator to AUTO mode, confirm all status lights are correct and the Generator Ready to Run is Green.
 4. Close all Enclosure doors and close the ADRES NEMA door.



Figure 1 Confirm all Enclosure Doors are Closed and Latched

ADRES Generator Control INSTALLATION MANUAL

Power Wiring for the ADRES Generator Control Module

Connecting 12 to 24 VAC or VDC Power to the Communication Board.

Description

The 66200 Communication board can be powered by either a 12 to 24 VAC or 12 to 24 VDC power supply. For all Generator applications the ADRES will use the Generator 12 or 24 VDC battery system.

Communication Board 66200-100

The 12 or 24 VDC Generator battery should be used to maintain consistent power even when utility AC power is unavailable. The ADRES control power will peak at 1.0 amp at 24 VDC when all relays are energized and the Cell modem is transmitting.

The ADRES should be connected directly to the battery source and the Communication board using AWG 18 or larger wire.

Note: There is a replaceable 5 Amp rated fuse on the communication board just above the On/Off switch SW 1 behind the terminal board.

APPROVED TRANSFORMERS

Model Number	Manufacturer	Available From	Input Rating	Output Rating

Communication Board 66200-XXX

The Communication board operates from 12 to 24 VDC or VAC supplied by the customer. Wiring to the Kohler Generator will always use the 24 VDC from the batteries.

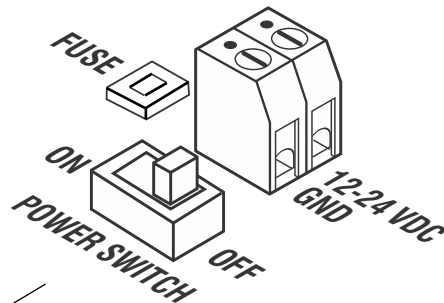
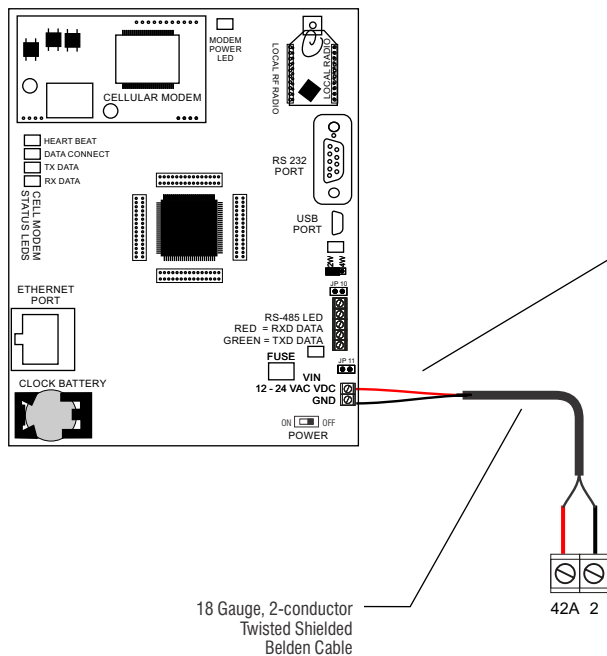

Power On/Off Switch

A switch is provided on the Communication Board for controlling all power to the Modem, Relay IO and Communication boards. Whenever wiring is changed or a board removed or installed, the power should be turned off by simply unplugging the terminal board at the communication board.

Caution!

Be sure to review the Wiring Workmanship requirements before any wiring is done.

To Generator Main Control Board
P/N GM 28725W120709
Terminal Board TB-1
Terminal 42A to +24 VDC
Terminal 2 for Ground.



Reference
WD 01

ADRES Generator Control WIRING INSTRUCTIONS

Communications Hard Wiring for the 66200 Communication Board

Hard wiring the ADRES Generator control module using the RS-485 port on the Kohler Generator

Description

The ADRES Generator control module must be hard wired to the Kohler Generator main board using the RS 485 Port on both the ADRES communication board and the Kohler Generator main board P/N GM 28725W120709.

Use Belden communication cable in conduit between the ADRES and the Generator control enclosure, the RS 485 2-wire network can be established following the wiring shown at the right:

After mechanically installing the Communication board and NEMA enclosure, connect the Belden Cable wires from the Comm board to the Kohler Generator main board P/N GM 28725W120709 as follows:

At the ADRES Comm Board	To the Kohler Main Board	Wire Color	Function
2W Tx Rx-	2W Tx Rx-	RED	RS 485 2 Wire
2W Tx Rx+	2W Tx Rx+	BLK	RS 485 2 Wire

Wiring Materials Required

1. Belden Communication Twisted Shielded, 3 or 4-Conductor, AWG20.

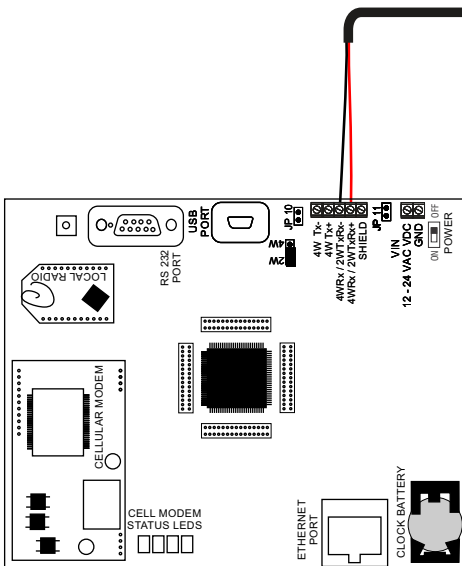

PN 66200 Communication Board
with Cellular Modem
with NEMA 4X Case

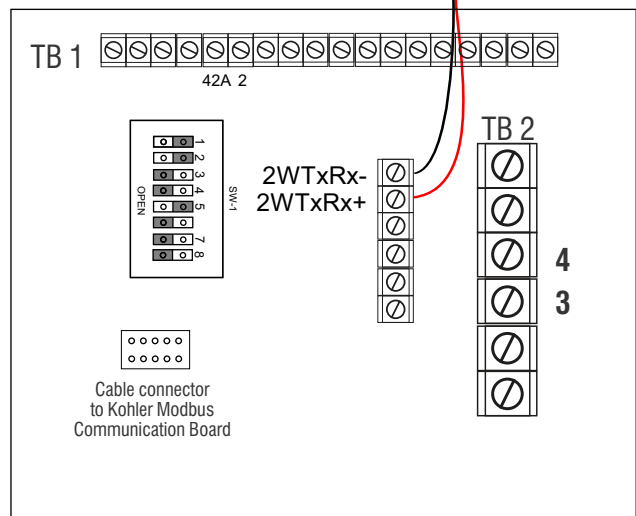

Kohler Generator Main Control Board
P/N GM 28725W120709
DEC 3 + Control

Caution!

Be sure to review the Wiring Workmanship requirements before any wiring is done.



Reference
WD 02

ADRES Generator Control WIRING INSTRUCTIONS

ADRES Generator Control Start / Stop Wiring Diagram

Description

The ADRES Generator control module is recommended to be hard wired to the Kohler Generator for providing the Generator a Start and Stop control input.

Use 18 Gage Belden Twisted Shielded cable in conduit between the ADRES and the Generator control enclosure.

After mechanically installing the ADRES Relay IO board connect the Belden Cable wires from the Relay IO board to the Kohler Generator main board P/N GM 28725W120709 as follows:

At the ADRES Comm Board	To the Kohler Main Board	Wire Color	Function
Relay 1 NO	Terminal TB2-4	BLK	Remote Start / Stop
Relay C 24	Terminal TB2-3	RED	Remote Start / Stop

The Remote Start / Stop terminals are dry contacts and not polarized and either wire can be connected to either terminal.

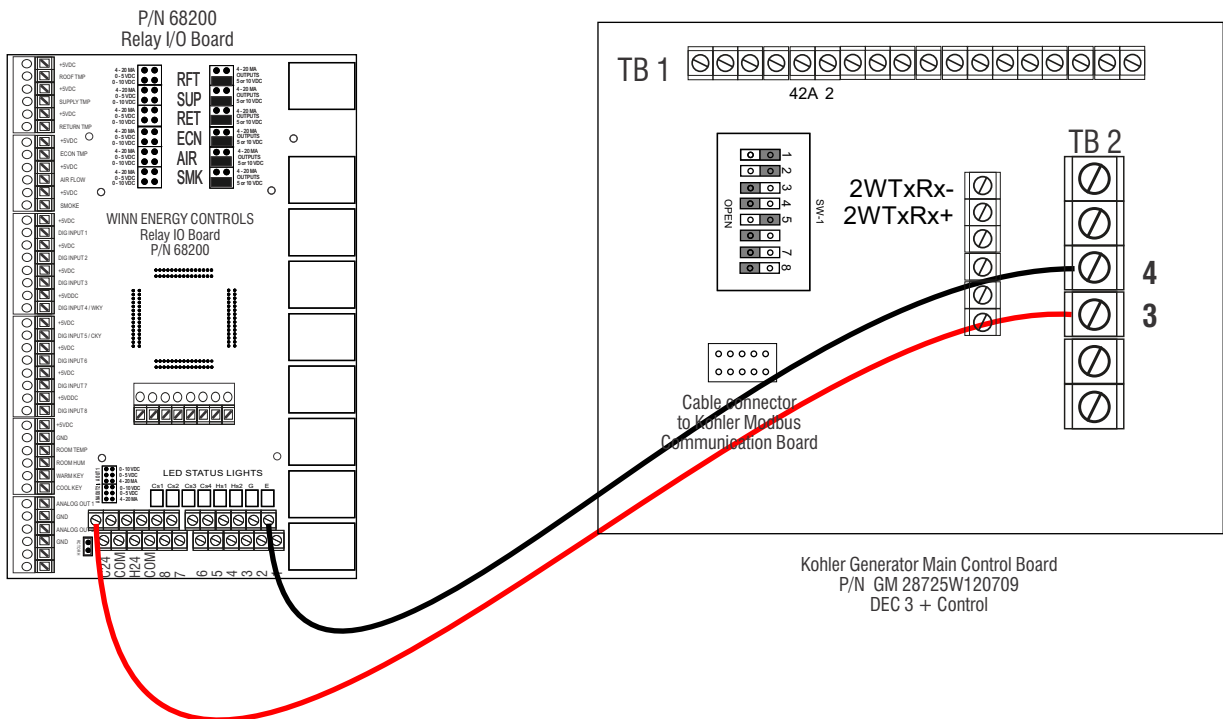

Caution!
Be sure to review the Wiring Workmanship requirements before any wiring is done.

Reference
WD 03



Safety First

Before you perform any wiring be sure you turn Off the power at the Generator. Failure to do so can result in personal injury and damage to the ADRES controls.

Local Electrical Codes

All wiring should meet all applicable electrical codes including any permit requirements.

Professional Installers

Only professional, experienced and qualified technicians should install these controls.

Approved Materials

Where applicable, only UL approved wire and supplies shall be used in the installation of these controls. Use only the size and type wire specified in the Wiring Diagrams.

Stripping and Installing Wires

The insulation on wires that are installed in the terminals on the control boards should be stripped about 1/4-inch being careful not to damage the conductor.

Insert the stripped conductor into the terminal and secure it with the screw. Always check that the wire is secure by gently tugging on it.

Insulation Damage Causes Electrical Shorts

The insulation on wires can be cut by sharp sheet metal and cause the conductor to short to earth ground. This provides a path for electrical damage during lightning strikes and can cause damage to the equipment.

Securing the NEMA Enclosure

The NEMA enclosure should be secured so that it cannot be damaged by technicians on the roof or be damaged by vibration. An unsecured NEMA enclosure can pose a personal hazard and potential damage to the equipment.



Winn Energy Controls, Inc.

2637 Ariane Drive

San Diego, CA 92117

Tel: (858) 274-1330

Fax: (858) 274-1362

Web: www.winnenergy.com

Email: sales@winnenergy.com